



# CARBON DIOXIDE ROOM SERIES

Installation & Operation Instructions  
A/CO2-R2

Phone: 1-888-967-5224  
Website: workaci.com

## GENERAL INFORMATION

The ACI Carbon Dioxide Room Series (A/CO2-R2) monitors the carbon dioxide (CO<sub>2</sub>) levels in commercial, school, and office-type environments. The concentration of CO<sub>2</sub> is a strong indication of the overall indoor air quality. The A/CO<sub>2</sub> Series is based on a single beam, non-dispersive infrared technology and is a cost-efficient solution for measuring carbon dioxide levels for building climate control. In addition, ABC software eliminates the need for manual calibration. Carbon Dioxide concentration is measured up to 2,000 ppm and is converted into proportional analog outputs. The factory default output is 4-20 mA, whereas 0-5 VDC and 0-10 VDC outputs are field selectable via integral dip switches. Thermistor temperature outputs, along with setpoint and override, are available as options for this configuration as well. The A/CO<sub>2</sub>-R2 Series provides data which can be used in conjunction with a Building Automation System or Demand Control Ventilation to decrease energy consumption while creating a healthier indoor climate.

## FIGURE 1: DIMENSIONS

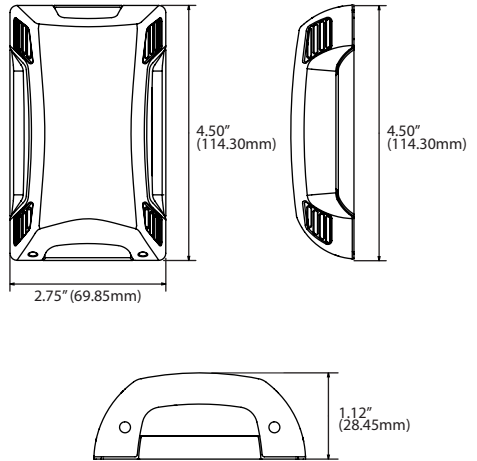

## MOUNTING INSTRUCTIONS

Separate the cover from the base. Attach the base directly to the wall or to a standard 2" x 4" junction box using the (2) #6-32 x 1" screws provided.

Take care when mounting. Check local code for mounting height requirements. Typical mounting heights are 48-60" (1.2-1.5 m) off the ground and at least 1.5' (0.5 m) from the adjacent wall. The sensor should be mounted in an area where air circulation is well mixed and not blocked by obstructions.

\*Reference FIGURE 2 (p. 2)

### For optimal temperature measurement:

- Do not install on external walls.
- Avoid air registers, diffusers, vents, and windows.
- Avoid confined areas such as shelves, closed cabinets, closets, and behind curtains.
- Eliminate and seal all wall and conduit penetrations. Air migration from wall cavities may alter temperature readings.
- A thermally-insulated backing should be used when fitting to solid walls (concrete, steel, etc.). ACI part: A/ROOM-FOAM-PAD
- Do not install near heat sources, eg: lamps, radiators, direct sunlight, copiers, chimney walls, walls concealing hot-water pipes.



Refer to the **Wiring Instructions** to make necessary connections. After wiring, attach the cover to the base by snapping the top of the cover on first and then the bottom. Tighten the cover down, using the (2) 1/16" Allen screws located in the bottom of the housing. A 1/16" Hex driver is needed to secure the cover to the base.

## WIRING

### PRECAUTIONS

- Do not run the temperature sensor wiring in any conduit with line voltage (24/120/230 VAC) if utilizing resistance temperature signal.
- Remove power before wiring. Never connect or disconnect wiring with power applied.
- When using a shielded cable, ground the shield only at the controller end. Grounding both ends can cause a ground loop.
- It is recommended you use an isolated UL-listed class 2 transformer when powering the unit with 24 VAC. Failure to wire the devices with the correct polarity when sharing transformers may result in damage to any device powered by the shared transformer.
- If the 24 VDC or 24VAC power is shared with devices that have coils such as relays, solenoids, or other inductors, each coil must have an MOV, DC/AC Transorb, Transient Voltage Suppressor (ACI Part: 142583), or diode placed across the coil or inductor. The cathode, or banded side of the DC Transorb or diode, connects to the positive side of the power supply. Without these snubbers, coils produce very large voltage spikes when de-energizing that can cause malfunction or destruction of electronic circuits.

### CO2 Wiring Instructions

Open the cover of the enclosure. ACI recommends 16 to 26 AWG twisted pair wires or shielded cable for all transmitters. Refer to **FIGURE 3** for wiring diagrams. All wiring must

**FIGURE 2: MOUNTING**

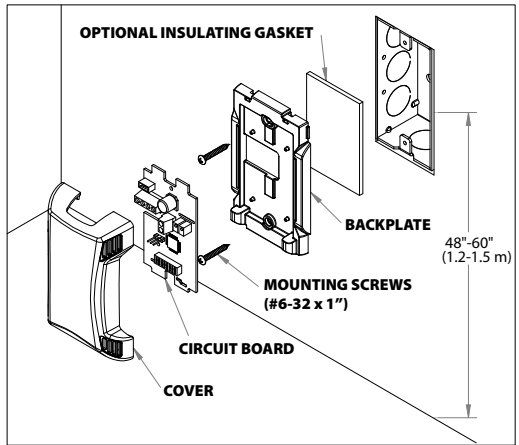

**FIGURE 3: CO2 WIRING**

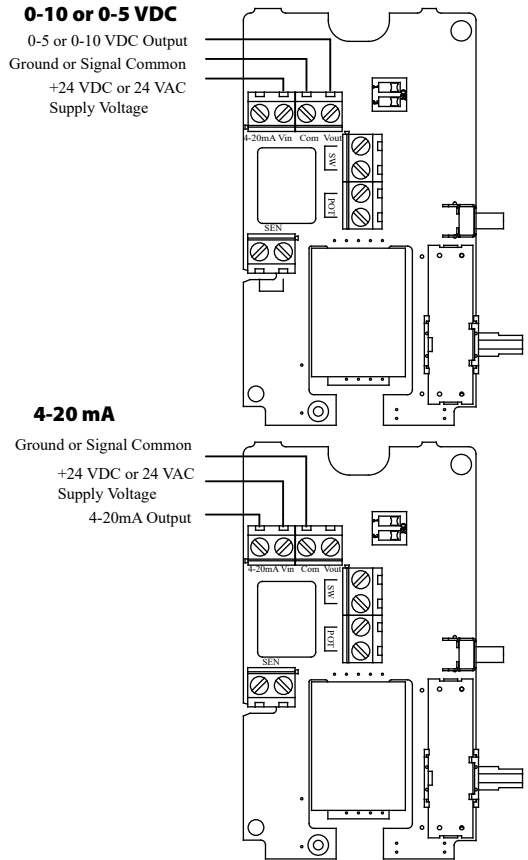

comply with all local and National Electric Codes.

**Note:** The 4-20mA output requires 3 wire.

**Temperature Wiring Instructions**

Signal wiring must be run separate from low and high voltage wires (24/120/230 VAC). All ACI thermistors and RTD temperature sensors are both non-polarity and non-position sensitive.

**Note:** When using a shielded cable, be sure to connect only (1) end of the shield to ground at the controller. Connecting both ends of the shield to ground may cause a ground loop. When removing the shield from the sensor end, make sure to properly trim the shield to prevent any chance of shorting.

Terminal Blocks	Connections
SEN	Temp. sensor signal to controller analog input
SEN	Temp. sensor signal common to controller analog input
POT	Temp. set point signal to controller analog input
POT	Temp. set point signal common to controller analog input
SW	Override signal to controller analog input
SW	Override signal common to controller analog input

When wanting to use a Single Common for all (3) of the Outputs, connect one wire in series with one of the Sensor, Setpoint, and Override Terminals. These three terminals may then be tied to the common of the controller with one wire, while the other three terminals would need to be connected to the proper Analog Inputs on your controller. Reference **FIGURE 4**.

**FIGURE 4: COMMON OUTPUT TO CONTROLLER**

**ANALOG SIGNAL COMMON OUTPUT TO CONTROLLER**

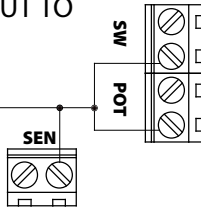

**DIP SWITCH CONFIGURATION**

SW 1 sets the Output Signal.  
SW2 controls the ABC Logic.

The default setting is 0-10 VDC output (switch 1 on) and ABC on (switch 2 on). For 0-5 VDC output set switch 1 to off. The 4-20 mA output can be used with switch 1 in the on or off position.

**FIGURE 5: DIP SWITCH SETTINGS**

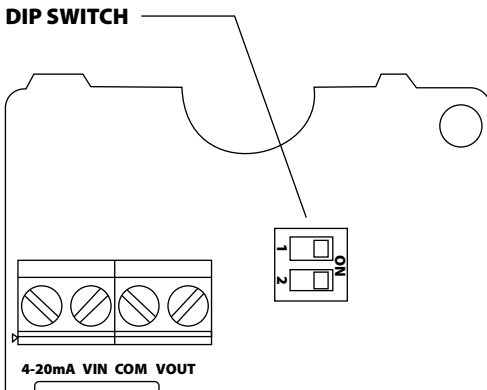

ABC stands for automatic baseline correction, a self-calibration function for achieving maintenance-free gas sensors. To turn off ABC, set switch 2 to off. The ABC Logic must be turned off in applications where there is 24/7 occupancy. ie: Hospital

**Calibration**

The A/CO2-R2 is basically maintenance free in normal environments thanks to the built-in self-correcting ABC algorithm. The ABC logic may need to be turned off in some applications, such as those with continuous occupancy.

**Note:** The sensor accuracy is defined at continuous operation (at least 3 weeks after installation).



# PRODUCT SPECIFICATIONS

<b>Supply Voltage:</b>	24 VAC +/-20%, 50/60 Hz (half-wave rectifier)   16.5-40 VDC Max.
<b>Power Consumption:</b>	3 VA for 24 VAC, 3W for 24 VDC (peak); <0.9W (average)
<b>Sensing Technology:</b>	Single beam infrared sensing technology (NDIR)
<b>Sensing Method:</b>	Diffusion
<b>Measurement Range Default:</b>	0 to 2,000 ppm
<b>Extended CO2 Ranges:</b>	Up to 10,000 ppm (factory set)
<b>Extended Range Accuracy:</b>	+/- 30 ppm and +/- 5% of reading
<b>CO2 Output Signal:</b>	<b>Output 1:</b> 0-5 VDC or 0-10 VDC (Default)   <b>Output 2:</b> 4-20 mA (500 Ohm Load maximum)
<b>Fail Safe:</b>	Polarity protected
<b>CO2 Accuracy <sup>1</sup>:</b>	+/- 40 ppm +/- 3% of reading (@ 15-35°C; 20-70% RH and 101.3 kPa)
<b>Pressure Dependence:</b>	+ 1.6% reading per kPa (deviation from standard pressure 101.3 kPa)
<b>Response Time:</b>	≤ 2 minutes, diffusion
<b>Warm-Up Time:</b>	< 1 minute (@ full specs < 15 minutes)
<b>Temperature Output Range:</b>	Various (see ordering grid)
<b>Temperature Accuracy:</b>	+/- 1°F (+/- 0.6°C)
<b>Operating Temperature Range:</b>	32 to 122°F (0 to 50°C)
<b>Operating Humidity Range:</b>	0 to 95%, non-condensing
<b>Connections   Wire Size:</b>	Screw Terminal Blocks   16 (1.31 mm <sup>2</sup> ) to 26 (0.129 mm <sup>2</sup> ) AWG
<b>Terminal Block Torque Rating:</b>	0.5 Nm (minimum); 0.6 Nm (maximum)
<b>Enclosure:</b>	ABS, Plastic, White, UL94-HB
<b>Sensor Coverage Area:</b>	7,500 sq. ft maximum
<b>Mounting Height:</b>	4-6 ft
<b>Sensor Life <sup>2</sup>:</b>	> 15 years (typical)
<b>Calibration <sup>3</sup></b>	ABC algorithm (Automatic Baseline Correction)

**Note 1:** Accuracy is defined after minimum three (3) ABC periods (1 period = 8 days) of continuous operations | **Note 2:** In normal indoor air quality (IAQ) applications | Corrosive environments are excluded | **Note 3:** Building CO2 levels must drop to 400 ppm same time during the week for ABC to work properly | If the building is occupied 24 hours / day, ABC must be turned off

## WARRANTY

The A/CO2-R2 Series is covered by ACI's Five (5) Year Limited Warranty, which is located in the front of ACI'S SENSORS & TRANSMITTERS CATALOG or can be found on ACI's website: [www.workaci.com](http://www.workaci.com).

