



INTERFACE SERIES

Installation & Operation Instructions
DRN4 - V2

Phone: 1-888-967-5224
Website: workaci.com

GENERAL INFORMATION

The DRN4 is a resistive output motor actuator interface that accepts several types of DDC system signals. The DRN4 output is 0 to 135 ohms. The input signal types are field selectable by an 8-position DIP switch. The floating point input accepts two digital signals, one for increase and the other for decrease. The floating point full scale rate of change is 55 seconds. Some triac input signals require an accessory. The DRN4 is supplied in an enclosure that can be directly mounted to a 1/2 inch knockout on the motor actuator. Color coded wire leads with spade connectors are provided for electrical connections. Some triac inputs require a Triac adapter kit. Johnson Control triac input signal requires a 1,000 ohm 1/2 watt resistor and is included with all DRN4s.

MOUNTING INSTRUCTIONS

Tools needed may include a Phillips screwdriver to remove actuator cover screws, 3 wire nuts for two signal and one common wire connections and a voltmeter for troubleshooting if necessary. Turn off power to the actuator and remove the actuator cover. Remove a knock-out on the actuator near the actuator control terminals. Open the access cover on the DRN4 and set the switches to the desired mode of operation. Replace the switch access cover on the DRN4 and remove the outermost lock-nut from the DRN4 box connector fitting. Feed the DRN4 wires through the actuator knock-out and the lock-nut. Tighten the lock-nut onto the DRN4 fitting. Connect the DRN4 leads with spade connectors to the correct actuator terminals, the external control source and the power source. Wire nut any unused wire and replace the actuator cover.

WIRING INSTRUCTIONS

PRECAUTIONS

- Remove power before wiring. Never connect or disconnect wiring with power applied.
- When using a shielded cable, ground the shield only at the controller end. Grounding both ends can cause a ground loop.
- It is recommended you use an isolated

FIGURE 1: DIMENSIONS

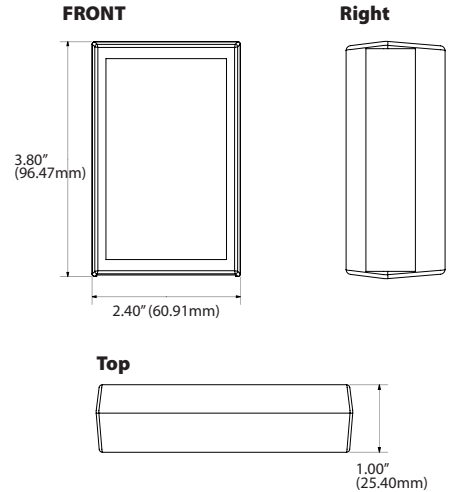
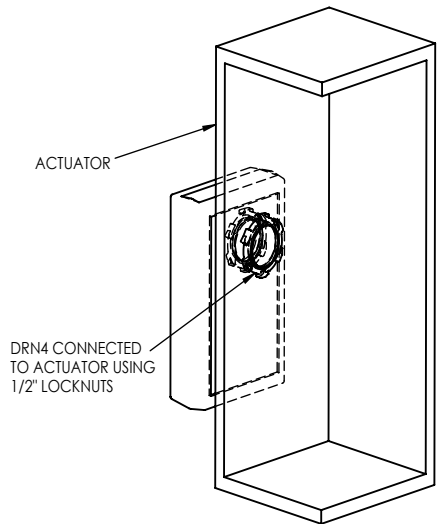

FIGURE 2: MOUNTING



WIRING INSTRUCTIONS (Continued)

UL-listed class 2 transformer when powering the unit with 24 VAC. Failure to wire the devices with the correct polarity when sharing transformers may result in damage to any device powered by the shared transformer.

- If the 24 VDC or 24VAC power is shared with devices that have coils such as relays, solenoids, or other inductors, each coil must have an MOV, DC/AC Transorb, Transient Voltage Suppressor (ACI Part: 142583), or diode placed across the coil or inductor. The cathode, or banded side of the DC Transorb or diode, connects to the positive side of the power supply. Without these snubbers, coils produce very large voltage spikes when de-energizing that can cause malfunction or destruction of electronic circuits.
- All wiring must comply with all local and National Electric Codes.

FIGURE 3: WIRING

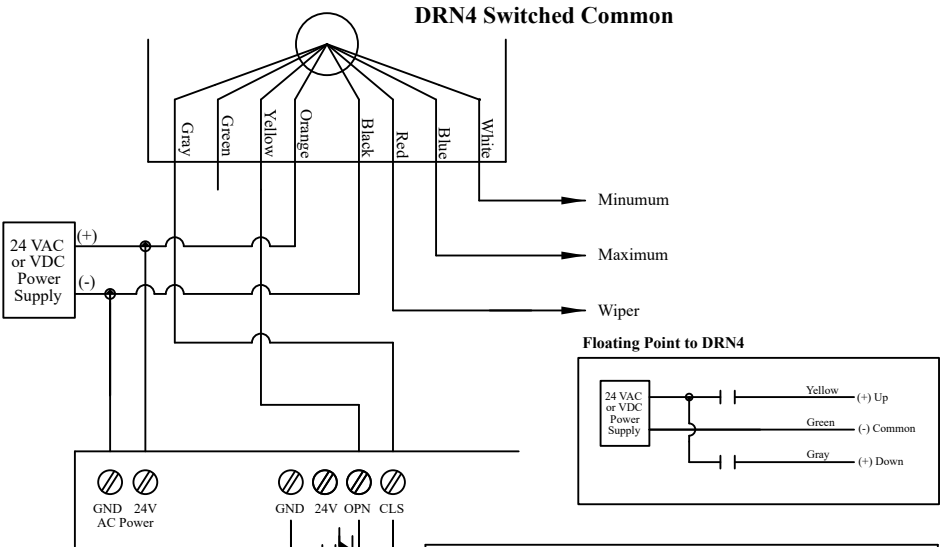

DRN4 WIRE TERMINATION ASSEMBLY GUIDE		
Color	Connection	Wire Termination
White	Motor W (min)	Female Spade
Blue	Motor B (max)	Female Spade
Red	Motor R (wiper)	Female Spade
Black	Motor T2	Female Spade
Orange	Motor T1	Female Spade
Black	24 VAC (-)	Male Spade
Orange	24 VAC (+)	Male Spade
Yellow	Floating Point Up/Analog/Pulse	Flying Leads
Green	Signal Common	Flying Leads
Gray	Floating Point Down	Flying Leads

FIGURE 4: WIRING

Analog Input to DRN4

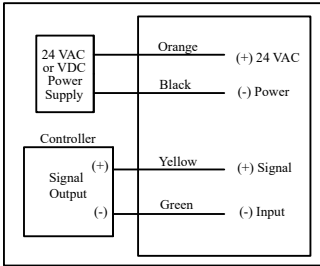

Pulse to DRN4

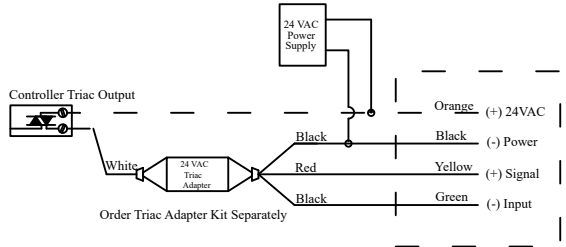
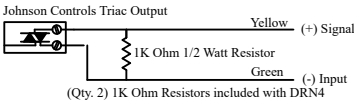
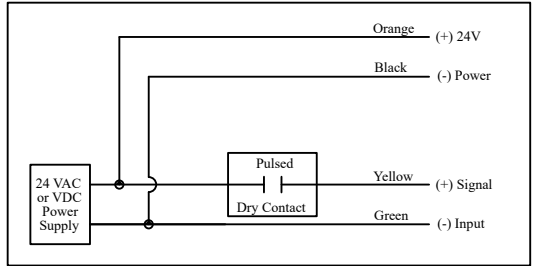
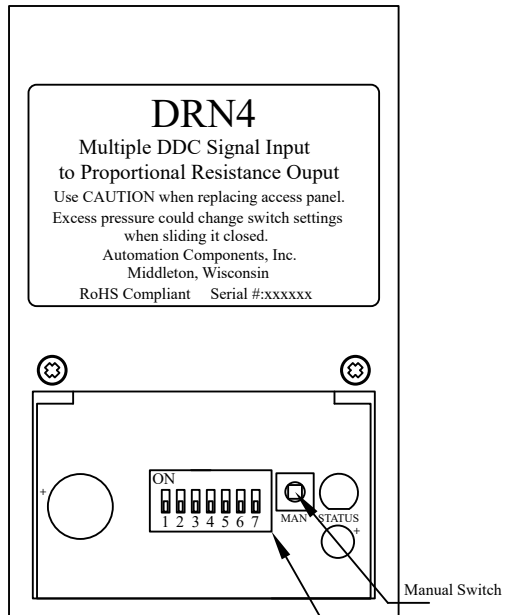
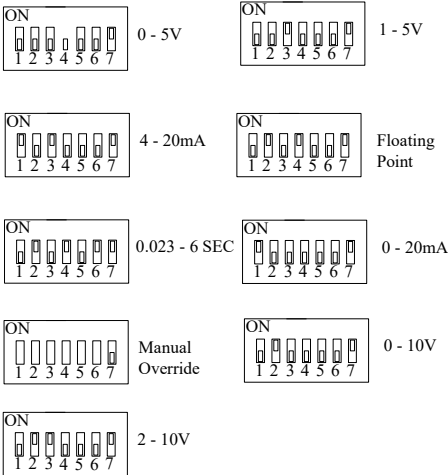

FIGURE 5: SWITCH SETTINGS



Use CAUTION when replacing access panel. Excess pressure could change switch settings when sliding it closed.

These switches are shown switched down in the OFF position.

CHECKOUT

After DIP switches for the signal input compatible with the external controller are set, power the actuator and have the external controller send a minimum signal and then a maximum command signal to verify proper actuator positioning. The LED under the cover will indicate according to the following:

MANUAL OPERATION WITH OVERRIDE BUTTON

Manual operation is allowed by placing dip switch (7) in the "OFF" position. Pressing override button allows you to manually simulate the input range selected by the DIP switches (analog, pulse or tri-state). (Note: Override button will NOT WORK in 1-5V, or 0-5V setting.)

ANALOG

Output ramps up while button is pressed (LED is off at 10VDC maximum signal), when released the output will begin ramping down to zero (LED is on at 0VDC minimum signal). Between minimum and maximum, the higher the input voltage, the shorter the LED pulse.

PULSE

Pressing override button simulates signal within the pulse range selected. LED flashes only when PWM signal is being received.

FLOATING POINT

Output will ramp up while button is pressed (55 seconds for a full scale) and remain at point of release. LED remains lit all the time. Remove power to DRN4 to reset to zero.

TRIAC INPUT

When using a triac input signal from an external controller, a Triac Adapter Kit must be ordered with the DRN4. Connect the black common (-) wire from the power source, and the black common wire on the triac adapter to the incoming power lead.

Suggestion: Clip off a short section of the power wire to include the female connector. Clip off the male spade connector on the DRN4 black lead, then wire nut triac adaptor lead, DRN4 lead, and the power wire with the female connector together. Plug into motor. Wire nut the triac adapter red wire and the DRN4 yellow wire together, the other triac adapter black wire and the DRN4 green wire together.

Johnson Control Triac input signals require only the installation of a 1K ohm ½ watt resistor. The resistor is added across the DRN4 signal input wires (yellow and green), and wire nut to the external controller signal leads. An added precaution would be to wrap resistor with electrical tape.

PRODUCT SPECIFICATIONS

NON-SPECIFIC INFORMATION	
Supply Voltage:	24 VAC or 24 VDC, +/-10%
Supply Current:	130 mA maximum
Input Voltage Signal Range (@ Impedance):	0 to 5 VDC 1 to 5 VDC 0 to 10 VDC 2 to 10 VDC @ 100,000Ω
Input Current Signal Range (@ Impedance):	0-20 mA, 4 to 20 mA @ 250Ω
Input Pulse Signal Source:	Relay Contact Closure, Transistor, Triac (Adapter Required)
Input Pulse Signal Trigger Level:	5-24 VDC/VAC
Off Time Between Pulses:	80 milliseconds
Pulse Ranges:	0.023 - 6 s
Floating Point / Tri-State Input Signal Source:	Relay, Contact Closure, Transistor, or Triac (Adapter Required)
Floating Point / Tri-State Rates of Change:	55 seconds for full output span
Floating Point / Tri-State Input Signal Trigger Level:	5-24 VDC/VAC
Resistive Output:	0 to 135Ω (3 watts)
Resolution:	32 steps
Digital Output Type:	Form "C" Relays
Relay Contact Rating:	1A @ 30 VDC / 125 VAC
Relay Electrical Life:	100,000 operation @ 1A
Relay Mechanical Life:	10,000,000 operations
Connections / Wire Size:	Color coded 18 AWG wire leads with spade connectors
Mounting:	Mounts directly to ½" knockout on actuator housing
Operating Temperature Range:	35 to 120°F (1.7 to 48.9°C)
Operating Humidity Range:	10 to 95% non-condensing
Storage Temperature:	-20 to 150°F (-28.9 to 65.5°C)

WARRANTY

The DRN4 Interface Series is covered by ACI's Two (2) Year Limited Warranty, which is located in the front of ACI'S SENSORS & TRANSMITTERS CATALOG or can be found on ACI's website: www.workaci.com.



NOTES

NOTES



NOTES

NOTES



