



**USER'S GUIDE**

# Freezer Series Sensor

## Installation & Operation Instructions



GD



4X



## **CONTACT**

### **Automation Components, Inc.**

[workaci.com/contact-us](http://workaci.com/contact-us)

**Telephone:**

**1-(888) 967-5224**

**Fax:**

**(608) 831-7407**

---

The information contained in this document is believed to be correct, but ACI accepts no liability for any errors it contains, and reserves the right to alter specifications without notice.



**Automation Components, Inc.**  
a DwyerOmega brand

# Table of Contents

<b>1. General Information</b> .....	<b>3</b>
<b>2. Mounting Instructions</b> .....	<b>4</b>
2.1. Enclosure Mounting.....	4
2.2. Wire Installation.....	4
2.3. Sensor Mounting .....	5
<b>3. Wiring Instructions</b> .....	<b>6</b>
<b>4. Troubleshooting</b> .....	<b>7</b>
<b>5. Product Specifications</b> .....	<b>7</b>

## 1. General Information

The ACI Freezer Series features a 4.76 mm (3/16 in) diameter stainless steel probe with a 3.05 m (10 ft) or 9.15 m (30 ft), 3 Conductor, 24 AWG Plenum rated jacketed Teflon cable. It is designed for use with electronic controllers in commercial heating and cooling building management systems. The Freezer sensors can be used with any of the Single or Triple Point Glycol Kits for use in applications where a Thermal Buffer (slower) response time is desired.

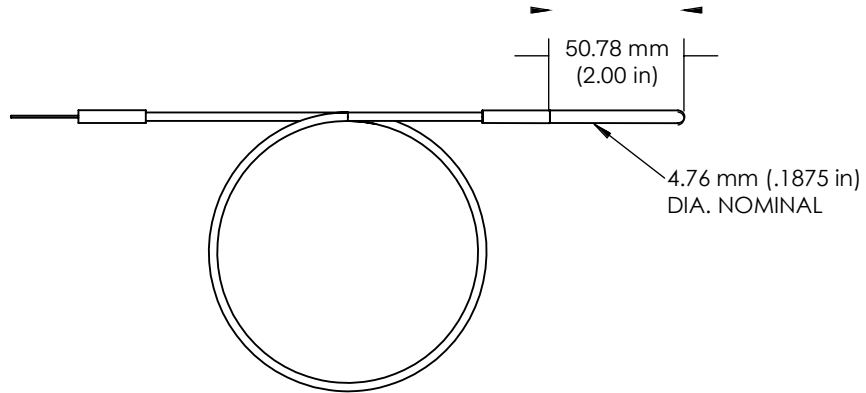
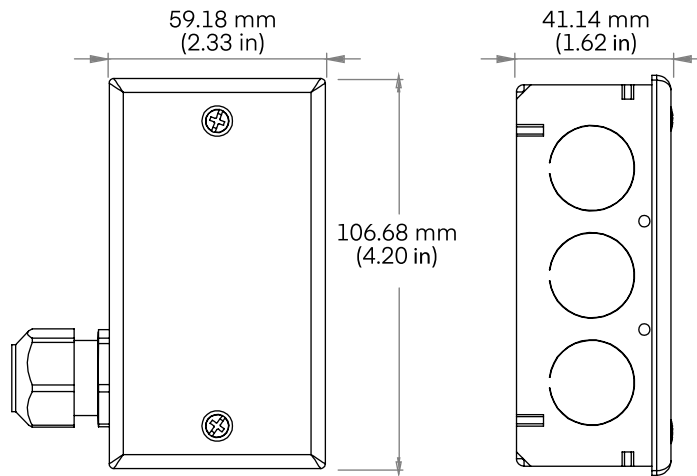

Figure 1: Freezer probe dimensions

## Galvanized (-GD)



## NEMA 4X (-4X)

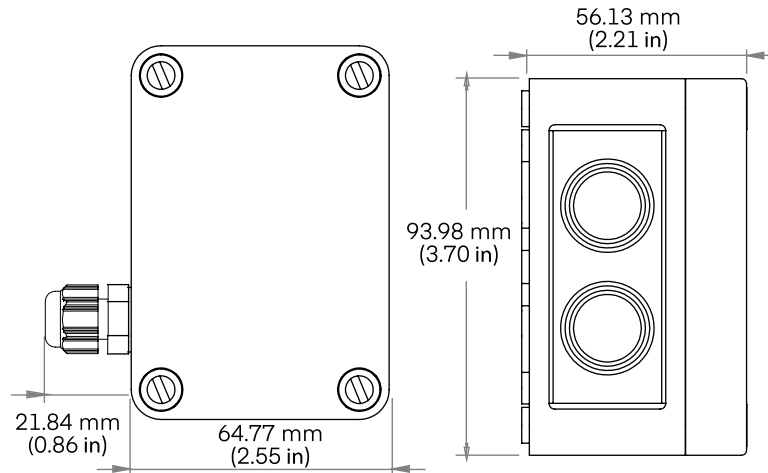

Figure 2: Enclosure dimensions

## 2. Mounting Instructions

### 2.1. Enclosure Mounting

The enclosure must be mounted outside of the freezer/cooler. On Vertical units, mount on the top of the freezer see **Figure 3**. On Horizontal units, mount on the backside or side of the freezer. Attach the base directly to the wall by using double sided tape.

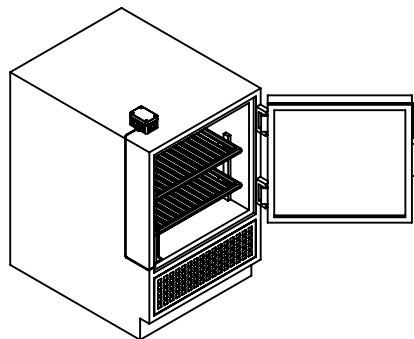
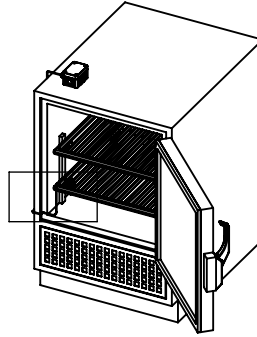

Figure 3: Enclosure mounting

### 2.2. Wire Installation

ACI recommends installing the wire through the door seal, probe access port, or cooler wall. On horizontal units, the preferred method is using the rear door seal as shown in **Figure 4**. On vertical units, remove the rear panel. There is typically a probe access hole. Probe and wires can be ran into that access hole. Alternatively, you can drill a hole just larger than the diameter of the wire (3.175 mm (0.125 in)) through the wall. From inside the cooler/freezer, push the wire through the hole. Use mounting clips to secure the wire to the interior wall or shelving. Use silicone caulking to seal the hole around the wire.



*Figure 4: Wire routing*

### 2.3. Sensor Mounting

Bullet Probe sensors can be wrapped around a shelf as shown in **Figure 5**. Alternatively, the sensor may be mounted on walls using a mounting clip. The sensor should be mounted in an area where air circulation is well-mixed and not blocked by obstructions. Slide the sensor probe through the mounting clip - see **Figure 6**. Drill a 1/4 in screw through the socket and tighten to the wall. If a thermal buffer is required, use a glycol kit (ACI Item #130127). Drill pilot holes for the provided mounting screws. Use the mounting clip holes as a guide - see **Figure 7**. Drill the #10-16 x 1/2 in screws through the bracket holes and fasten it to the wall. Insert the bottle into the bracket, and make sure it is seated securely.

---

#### Note

When using in tank or glycol application, the sensor cannot be fully submerged. The back end of the probe (where the wire enters), must be kept above the liquid.

---

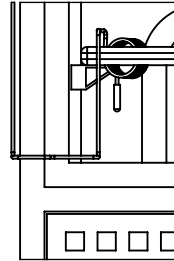

Figure 5: Sensor mounting

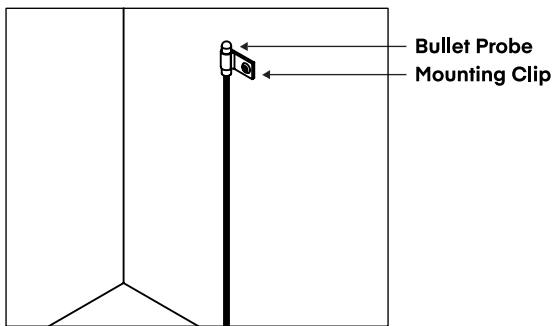

Figure 6: Sensor mounting on wall

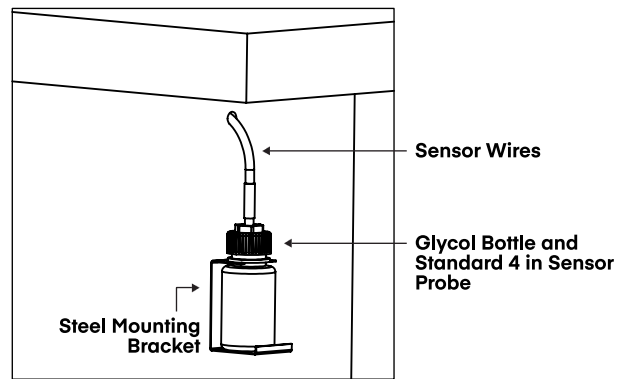

Figure 7: Glycol Sensor with Bracket

### 3. Wiring Instructions

ACI recommends 16 AWG to 26 AWG twisted pair wires or shielded cables for all sensors. Signal wiring must be run separate from low and high voltage wires (24 Vac / 120 Vac / 230 Vac). All ACI temperature sensors are non-position sensitive. All freezer sensors are supplied with (3) flying lead wires – see **Figure 8**.

Connect sensor wire leads to controller analog input wires using wire nuts, terminal blocks, or crimp style connectors. All wiring must comply with all local and National Electric Codes.

---

#### Note

When using a shielded cable, be sure to connect only (1) end of the shield to ground at the controller. Connecting both ends of the shield to ground may cause a ground loop. When removing the shield from the sensor end, make sure to properly trim the shield to prevent any chance of shorting.

#### Note

If the controller requires a (2) wire input for a RTD, connect the (2) common wires(same color) together. If the controller requires (3) wires, use (3) individual wires.

---

### 3-Wire RTD Wiring

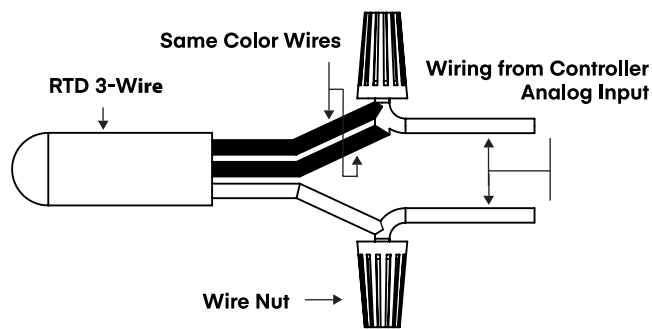

Figure 8: Temperature wiring - 3-wire RTD wiring

#### 4. Troubleshooting

Problem	Solution(s)
Sensor reading is incorrect	<ul style="list-style-type: none"> <li>Verify sensor wiring to controller is not damaged and has continuity.</li> <li>Verify sensor or wires are not shorted together.</li> <li>Verify controller is setup for correct sensor curve.</li> <li>Disconnect wires from sensor terminal block, tighten terminal block screws down, and take a resistance (ohm) reading with a multimeter.</li> <li>Compare the resistance reading to the Temperature Vs Resistance Curves online: <a href="http://www.workaci.com/content/thermistor-curves-0">http://www.workaci.com/content/thermistor-curves-0</a></li> <li>Verify proper mounting location to confirm no external factors are affecting reading.</li> </ul>
Sensor reads infinity/very high resistance	<ul style="list-style-type: none"> <li>Sensor or wires are open.</li> </ul>
Sensor reads low resistance	<ul style="list-style-type: none"> <li>Sensor or wires are shorted together.</li> </ul>
Erratic readings	<ul style="list-style-type: none"> <li>Condensation on PCB board</li> <li>Bad wire connections.</li> </ul>

#### 5. Product Specifications

##### General

<b>Storage Temperature Range:</b>	-40 °C to 80 °C (-40 °F to 176 °F)
<b>Operating Humidity Range:</b>	10 % to 100 % RH
<b>Lead Length   Cable Diameter:</b>	3.05 m (10 ft) or 9.15 m (30 ft)   2.69 mm nominal (0.106 in)
<b>Lead Wire Insulation   Jacket Color:</b>	FEP/FEP (Teflon) Jacketed Cable   White
<b>Conductor Size   Conductor Material:</b>	0.51 mm (24 AWG)   Silver Plated Copper
<b>Probe Material   Length   Diameter:</b>	316 Stainless Steel   50.8 mm (2 in)   4.76 mm (0.1875 in) nominal
<b>Enclosure Specifications:</b>	<p>"-GD": -40 °C to 100 °C (-40 °F to 212 °F); Galvanized Steel; NEMA 1 (IP10)</p> <p>"-4X": -40 °C to 70 °C (-40 °F to 158 °F); Polystyrene Plastic, UL94-V2, IP66 (NEMA 4X)</p>
<b>Cleaning Solutions Compatibility:</b>	Alcohol, Ammonia, Bleach, Hydrogen Peroxide

##### 1k / 100 ohm RTD Sensor

<b>Sensor Type   Sensor Curve:</b>	Platinum RTD   Linear, PTC (Positive Temperature Coefficient)
<b>DIN Standard   Temp Coefficient</b>	DIN EN 60751 (IEC 751)   3850 ppm / °C
<b>Response Time (63 % Step Change):</b>	15 Seconds nominal
<b>Sensor Output @ 0 °C (32 °F):</b>	<b>A/100-LTS Series:</b> 100 Ω nominal   <b>A/1K-LTS Series:</b> 1K Ω nominal
<b>Sensor Tolerance Class:</b>	<p><b>Class B Accuracy Formula:</b> <math>\pm \text{ }^\circ\text{C} = (\pm 0.30 \text{ }^\circ\text{C} + (0.005 \times  t ))</math>            where t is the Absolute Value of temperature in °C above or below 0 °C</p> <p><b>-200 °C (-328 °F):</b> <math>\pm 1.30 \text{ }^\circ\text{C}</math> (<math>\pm 2.34 \text{ }^\circ\text{F}</math>)   <b>0 °C (-32 °F):</b> <math>\pm 0.30 \text{ }^\circ\text{C}</math> (<math>\pm 0.54 \text{ }^\circ\text{F}</math>)</p>
<b>Sensor Operating Temperature Range:</b>	-198 °C to 150 °C (-324 °F to 302 °F)

##### Thermistor Sensor (1.8K, 3K, AN, CP, CSI, 20K)

<b>Sensor Type   Sensor Curve</b>	Thermistor   Non-Linear, NTC (Negative Temperature Coefficient)
<b>Sensor Output @ 25 °C (77 °F)</b>	<b>A/1.8K:</b> 1.8K Ω nominal   <b>A/CP (Type II):</b> 10K Ω nominal   <b>A/20K:</b> 20K Ω nominal   <b>A/3K:</b> 3K Ω nominal   <b>A/AN (Type III):</b> 10K Ω nominal   <b>A/CSI:</b> 10K Ω nominal
<b>Accuracy 0 °C to 70 °C (32 °F to 158 °F):</b>	<p><math>\pm 0.2 \text{ }^\circ\text{C}</math> (<math>\pm 0.36 \text{ }^\circ\text{F}</math>) except A/CP Series &amp; <b>A/AN Series:</b> <math>\pm 0.85 \text{ }^\circ\text{C}</math> (<math>\pm 1.53 \text{ }^\circ\text{F}</math>);</p> <p><b>A/1.8K Series:</b> <math>\pm 0.5 \text{ }^\circ\text{C}</math> @ 25 °C (77 °F) and <math>\pm 1.0 \text{ }^\circ\text{C}</math> (<math>\pm 1.8 \text{ }^\circ\text{F}</math>)</p>
<b>Response Time (63 % Step Change):</b>	15 Seconds nominal
<b>Sensor Operating Temperature Range:</b>	-40 °C to 150 °C (-40 °F to 302 °F)
<b>Agency Approvals:</b>	CE, UKCA, RoHS3, WEEE

## **WARRANTY**

The ACI Freezer Temperature Series temperature sensors are covered by ACI's Five (5) Year Limited Warranty, which is located in the front of ACI'S SENSORS & TRANSMITTERS CATALOG or can be found on ACI's website: [www.workaci.com](http://www.workaci.com).

## **W.E.E.E. DIRECTIVE**

At the end of their useful life the packaging and product should be disposed of via a suitable recycling centre. Do not dispose of with household waste. Do not burn.



**Automation Components, Inc.**  
a DwyerOmega brand

**workaci.com**



Version 7.0

**DWYEROMEGA™**  
Improving the world, one measurement at a time.™

