

2 YEAR
WARRANTY



Ω OMEGA™ **User's Guide**

*Shop online at
omega.com*

*e-mail: info@omega.com
For latest product manuals:
www.omegamanual.info*



OS-TX-USB-Series
Fixed IR Temperature
Transmitter with 4-20 mA and
MODBUS over USB outputs



omega.com info@omega.com

Servicing North America:

**U.S.A.
Headquarters:**

Omega Engineering, Inc.
Toll-Free: 1-800-826-6342 (USA & Canada only)
Customer Service: 1-800-622-2378 (USA & Canada only)
Engineering Service: 1-800-872-9436 (USA & Canada only)
Tel: (203) 359-1660
Fax: (203) 359-7700
e-mail: info@omega.com

For Other Locations Visit omega.com/worldwide

OS301A-USB Model infrared sensors measure the temperature of surfaces without contact. They provide this measurement as a linear 2-wire 4 to 20 mA output, which is compatible with almost any indicator, controller, recorder or data logger without the need for special interfacing or signal conditioning.

A choice of measurement wavelengths and temperature ranges is available to suit a range of applications.

General-purpose OS301A-USB (8-14 μm) models can measure from -40°C to 1000°C . They are suitable for measuring high-emissivity materials such as paper, thick plastics, food, pharmaceuticals, rubber, asphalt and painted surfaces.

Short-wavelength OS150A-2USB (2.2 μm) models have a choice of temperature ranges from 45°C to 2000°C . They provide a more accurate reading when measuring lowemissivity materials such as many reflective metals. They are also capable of measuring through glass viewports.

GENERAL SPECIFICATIONS

Model	OS150A-2USB	OS301A-USB
Spectral Response	2.2 μm	8 to 14 μm
Application	Ferrous metals and high-temperature targets	General purpose
Temperature range	Choice of ranges from 45°C to 2000°C	-40°C to 1000°C
Response time	200 ms	
Output	2-wire, 4-20 mA, linear with measured temperature	
Communications	USB 2.0 (removable USB cable and software included) using the Modbus protocol	
Optics	Choice of divergent or focused optics for small or large targets at short or long distances (see Optics)	
Accuracy	$\pm 2^{\circ}\text{C}$ or 1% of reading, whichever is greater	$\pm 1^{\circ}\text{C}$ or 1% of reading, whichever is greater
Repeatability	$\pm 0.5^{\circ}\text{C}$ or 0.5% of reading, whichever is greater	
Emissivity Setting	0.1 to 1.0	
Maximum Span (4-20 mA output)	Full temperature range	
Minimum Span (4-20 mA output)	100°C	

ELECTRICAL SPECIFICATIONS	
Supply Voltage	24 V DC (28 V DC max)
Sensor Voltage (minimum)	6 V DC
Maximum Loop Impedance	900Ω @ 24 V DC

MECHANICAL SPECIFICATIONS

Construction	Stainless Steel
Dimensions	Ø 27.6 x length 61 mm including cable glands
Thread mounting	M20 x 1 mm pitch, length 15 mm
4-20 mA Output Cable Length	1 m (standard), up to 30 m (optional)
Weight with 1 m Output Cable	155 g
USB Cable Length	1.8 m

ENVIRONMENTAL SPECIFICATIONS

Environmental Rating	IP65
Ambient (Operating) Temperature	0°C to 70°C (cooled models are available for higher temperatures)
Relative Humidity	95% max. non-condensing

MINIMUM MEASURABLE TEMPERATURE (model OS151A-2USB-LT only)

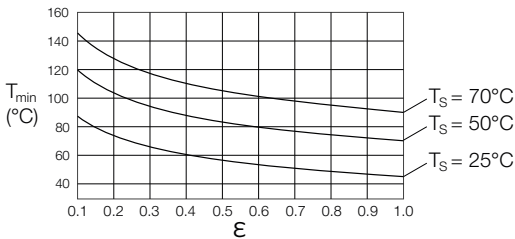

Graph showing the minimum measurable object temperature (T_{min}), determined by surface emissivity (ϵ) and sensor temperature (T_s).

Only applies when measuring low temperatures with model OS151A-2USB-LT.

DIMENSIONS

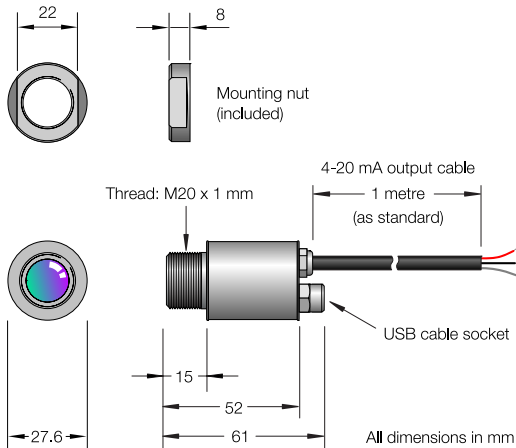

ACCESSORIES

A range of accessories to suit different applications and industrial environments is available. These may be ordered at any time and added on-site. The accessories consist of the following parts .

- Fixed and adjustable mounting brackets
- Air purge collar
- Laser sighting tool
- Mounting bracket with continuous laser sighting

OPTIONS

The following options are available. Options are factory installed and may only be ordered with a new sensor.

- Air/water cooled housing
- Certificate of calibration
- Longer cable (30 m max.)

OPTICAL CHART

The optical chart below indicates the nominal target spot diameter at any given distance from the sensing head and assumes 90% energy. It is possible to measure at longer distances than the diagrams show, with a larger measured spot size. There is no maximum measurement distance in clear air.

Optics (OS301A-USB Model)

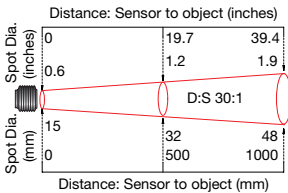

OS301A-USB

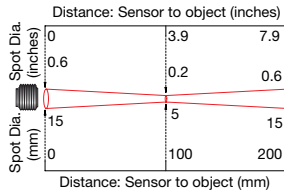

OS801A-USB

Optics (OS150A-2USB Model)

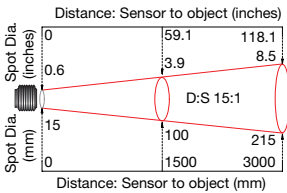

OS151A-2USB

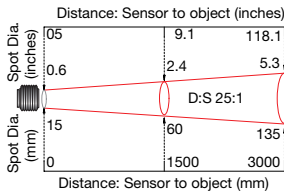

OS251A-2USB

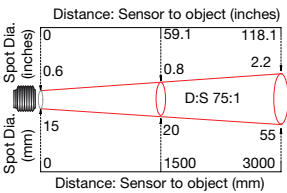

OS751A-2USB

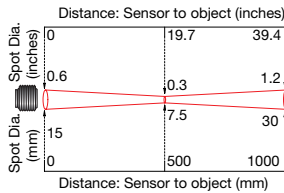

OS801A-2USB

INSTALLATION

The installation process consists of the following stages:

- 1 Preparation
- 2 Mechanical installation
- 3 Electrical installation

Please read the following sections thoroughly before proceeding with the installation.

PREPARATION

Ensure that the sensor is positioned so that it is focused on the target only.

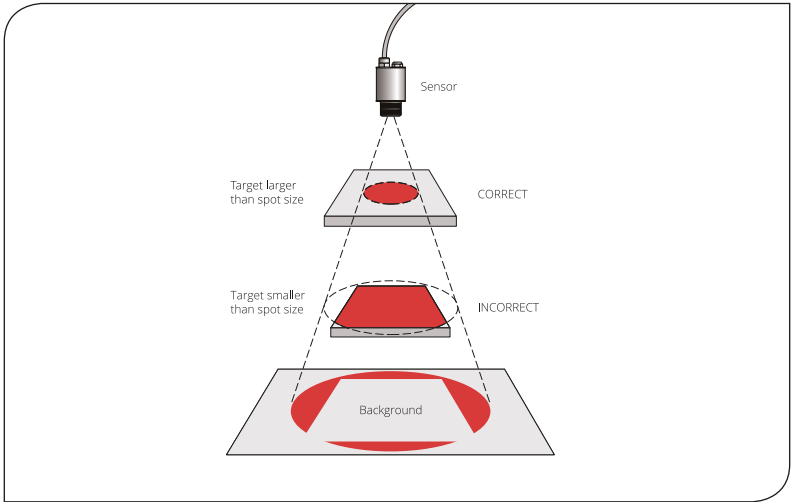

DISTANCE AND SPOT SIZE

The size of the area (spot size) to be measured determines the distance between the sensor and the target. The spot size must not be larger than the target. The sensor should be mounted so that the measured spot size is smaller than the target.

REFLECTIONS

The sensor must be installed in a location where energy from lamps, heaters and sunlight cannot be reflected from the target into the lens. The use of shields may help in this respect. For further information and assistance contact Omega.

AMBIENT TEMPERATURE

The sensor is designed to operate in ambient temperatures from 0°C to 70°C. For ambient temperatures above 70°C, an air/water-cooled housing will be required. Avoid thermal shock. Allow 20 minutes for the unit to adjust to large changes in ambient temperature.

ATMOSPHERIC QUALITY

Smoke, fumes or dust can contaminate the lens and cause errors in temperature measurement. In these types of environment the air purge collar should be used to help keep the lens clean.

ELECTRICAL INTERFERENCE

To minimise electromagnetic interference or 'noise', the sensor should be mounted away from motors, generators and such like.

WIRING

Check the distance between the sensor and the indicating/controlling device. If necessary, the sensor can be ordered with a longer cable attached.

POWER SUPPLY

Be sure to use a 24 V DC (22 mA) power supply.

MECHANICAL INSTALLATION

All sensors come with a 1m cable and a mounting nut. The sensor can be mounted on brackets or cut outs of your own design, or you can use the fixed and adjustable mounting bracket accessories which are shown below.

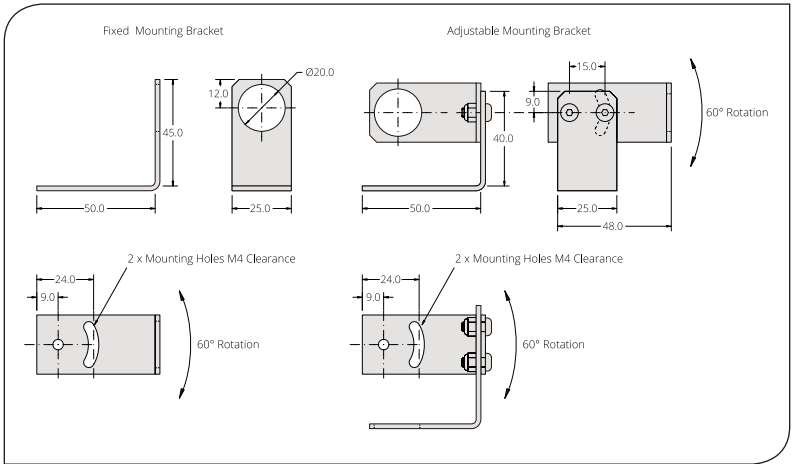

AIR/WATER COOLED HOUSING

The air/water cooled housing shown below allows the sensor to withstand high ambient temperatures. It is equipped with two 1/8" BSP fittings. Water temperature should be 10°C to 27°C for efficient cooling. Chilled water below 10°C is not recommended. To avoid condensation, the air purge collar should be used with the water-cooled housing. Water flow rate should be 0.5 to 1.5 litres/min. Adjust the flow rate and temperature of the cooling fluid to keep the sensor body between 0°C and 70°C.

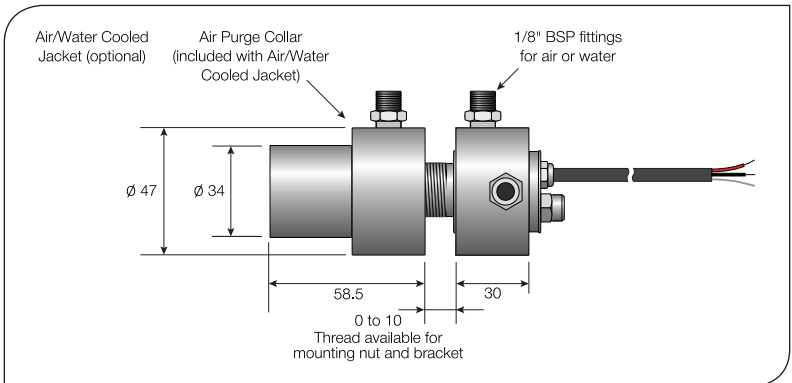

AIR PURGE COLLAR

The air purge collar below is used to keep dust, fumes, moisture, and other contaminants away from the lens. It must be screwed in fully. Air flows into the 1/8" BSP fitting and out of the front aperture. Air flow should be 5 to 15 litres/min.

Clean or 'instrument' air is recommended.

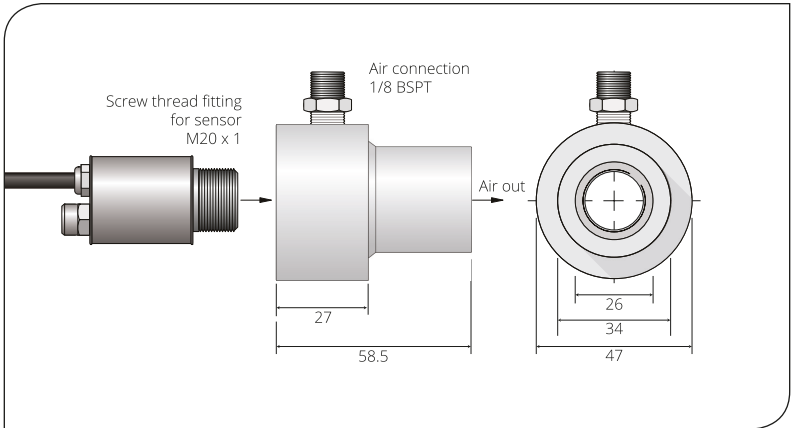

ELECTRICAL INSTALLATION

The 4-20 mA output cable is 1 m long as standard. The outer jacket is PVC. One end is attached, at the factory, to the sensor head. The other end has a pair of wires for the loop-powered 4-20 mA output and a shield (ground) wire.

WIRING

The sensor can be used in 3 different ways as shown below. To use the 4-20 mA output, connect the sensor to the controller/indicator with the 24 V DC power supply in the loop using the following table and connection diagram as a guide. The maximum loop impedance is 900 ohms.

Note: The sensor must be grounded at only one point, either the cable shield or the sensor housing.

Output	Wire No.	Wire Colour	Function
4 to 20 mA	1	Red	Power supply + / signal +
	2	Black	Power supply - / signal -
-	3	Bare	Shield ground

Alternatively, to use the USB output, connect the sensor to a PC using the cable provided. No external power supply is required when using the USB output. The sensor can also be used with both the 4-20 mA loop and USB connected, provided that the negative terminal of the 24 V DC power supply being used is not grounded.

Note: The software must be installed before connecting the sensor to a PC.

CONNECTIONS

The sensor will operate with either the 4 to 20 mA cable connected, the USB cable connected, or both.

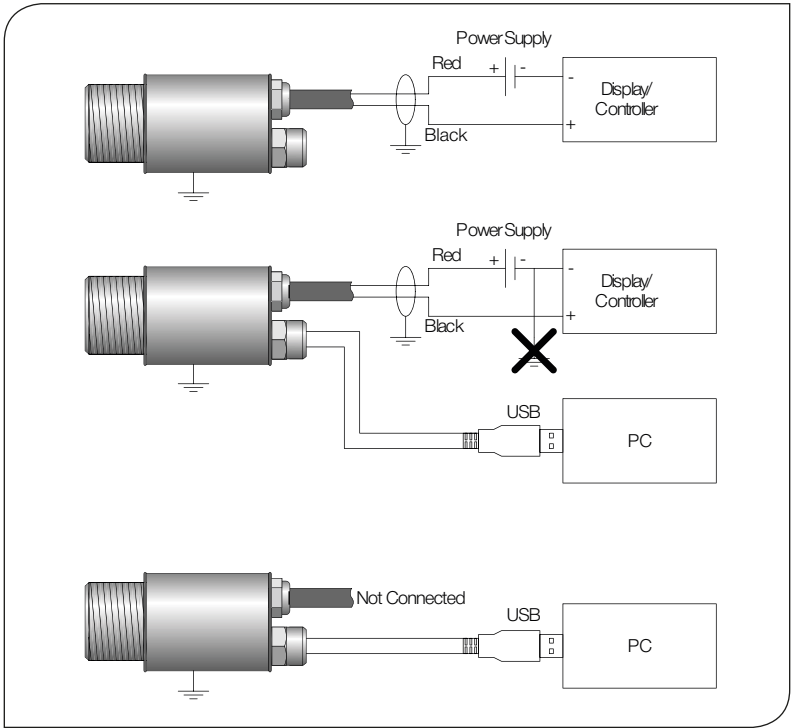

SOFTWARE

The sensor may be used with the free OmegaConfig software or third-party Modbus software.

System Requirements

- Windows Vista or newer
- USB 2.0 port, Internet access (for software download)

Installation

- 1 Download the software from the Omega website
- 2 Unzip and run setup.exe
- 3 Follow the on-screen instructions

NOTE: Do not connect the sensor to the PC before the software is installed.

CONNECTING THE SENSOR TO A PC

- 1 Connect the circular connector on the USB cable provided to the sensor
- 2 Connect the USB A connector on the USB cable provided to an available USB 2.0 port
- 3 Double click on the software desktop icon

CONFIGURATION

Configuration settings are password protected. To access the Settings menu, go to the Unlock screen and enter the password. **The default password is 1234.**

Temperature Units

On the temperature display screen, click °C or °F to switch between temperature units.

Output Processing

Go to the Settings screen, then Output Processing.

4 to 20 mA output scale

Set the temperature range limits for the 4 to 20 mA output. The temperature limits depend on the sensor model (see Model Numbers). Ensure the temperature range on the measurement instrument matches the 4-20 mA output scale.

Default setting: Full temperature range (depending on model).

The difference between the temperatures at 4 mA and at 20 mA must be at least 100°C. The temperature at 20 mA must be greater than the temperature at 4 mA.

Averaging period

Set the time, in seconds, over which the measured temperature is averaged. Note: averaging prevents the sensor from following rapid temperature changes.

Default setting: 0.

Peak/valley hold processing

If required, hold processing can be applied by setting Hold Mode to "Peak" or "Valley" and setting the hold period. This is useful if the temperature reading is interrupted by gaps between moving objects, or by an obstruction.

Default settings: Hold Mode: Off
Hold Period: 0

Emissivity and Compensation

From the Settings menu, go to Emissivity and Compensation.

Emissivity Setting

Enter the emissivity of the target. Target emissivity can be determined experimentally, or estimated using an emissivity table. For more information, contact Omega.

Default setting: 0.95

Window Transmissivity

When aiming the sensor through an IR-transmissive window, this setting should be adjusted to compensate for the presence of the window. Enter the transmissivity of the window. Enter "1" if no window is present.

Default Setting: 1

Reflected Energy Compensation On/Off

If enabled, compensates for errors caused by reflected energy from hotter or colder objects.

Default setting: Off

Reflected Temperature

Enter the temperature of the surroundings of the target for Reflected Energy Compensation.

Changing this setting has no effect when Reflected Energy Compensation is Off.

MODBUS OVER SERIAL LINE

Interface

Baud rate	9600
Format (bits)	8 data, No parity, 1 stop
Reply delay	20 ms

Supported Functions

Read register	0x03, 0x04
Write single register	0x06
Write multiple register	0x10

List of Modbus Addresses

The list below includes all available addresses:

R = Read, W = Write

Address	Length (words)	Description	R/W
0x00	1	Sensor Type 21 = OS301A-USB, 22 = OS150A-2USB	R
0x01	1	Field of view: OS301A-USB: 0 = 30:1, 1 = CF OS150A-2USB: 0 = 15:1, 1=25:1, 2 = 75:1, 3 = CF	R
0x02	2	Serial number	R
0x04	1	Temperature range (OS150A-2USB only): 0 = LT, 1 = PT, 2 = MT, 3 = HT	R
0x05	1	Modbus slave address	R/W
0x06	1	Reflected Energy Compensation 0 = Off, 1 = On	R/W
0x07	1	Reflected Temperature	R/W
0x08	1	Emissivity (1 LSB = 0.0001) Minimum 0.1000, Maximum 1.0000	R/W
0x09	1	Window Transmissivity (1 LSB = 0.0001) Minimum 0.2000, Maximum 1.0000 For when using the sensor with an IR window	R/W
0x0A	1	Output Scale: Temperature at 4 mA	R/W
0x0B	1	Output Scale: Temperature at 20 mA	R/W
0x0C	1	Hold Mode 0 = Off, 1 = Peak, 2 = Valley	R/W
0x0D	1	Hold Period (1 LSB = 0.1 seconds) Minimum 0, maximum 1200.0 s	R/W
0x0E	1	Average Period (1 LSB = 0.1 seconds) Minimum 0, maximum 60.0 s	R/W
0x0F	1	Average Temperature	R
0x10	1	Minimum Temperature	R

Address	Length (words)	Description	R/W
0x11	1	Maximum Temperature	R
0x12	1	Filtered Temperature	R
0x13	1	Unfiltered Temperature	R
0x14	1	Sensor Temperature	R
0x15	1	Status (bits active high): Bit 0: Measurement error Bit 1: Sensor temperature low Bit 2: Sensor temperature high Bit 3: Object temperature low Bit 4: Object temperature high	R
0x17	1	Reflected Temperature Not saved to non-volatile memory Use this register when writing frequently	R/W
0x18	1	Emissivity (1 LSB = 0.0001) Minimum 0.1000, Maximum 1.0000 Not saved to non-volatile memory Use this register when writing frequently	R/W

Notes:

- 1 All temperature are in tenths of degrees C
- 2 With the exception of addresses 0x17 and 0x18, all write operations are saved to non-volatile memory
- 3 For further information please refer to <http://www.modbus.org/specs.php>
- 4 The default Modbus slave address of the sensor is 1; it is also possible to use slave address 255 to communicate. 1 sensor may be connected per COM port.

DEFAULT SETTINGS

Modbus Slave Address	1
Emissivity Setting	0.95
Reflected Energy Compensation	Off
Window Transmissivity	1
4-20 mA Output Scale	Full temperature range, depending on model
Hold Mode	Off
Hold Period	0
Average Period	0

OPERATION

Once the sensor is in position and the appropriate power, air, water, and cable connections are secure, the system is ready for continuous operation by completing the following simple steps:

- 1 Turn on the power supply
- 2 Turn on the instrument or PC
- 3 Read / monitor the temperature

IMPORTANT

Be aware of the following when using the sensor:

- If the sensor is exposed to significant changes in ambient temperature (hot to cold, or cold to hot), allow 20 minutes for the temperature to stabilise before taking or recording measurements.
- Do not operate the sensor near large electromagnetic fields (e.g. around arc welders or induction heaters).
- Electromagnetic interference can cause measurement errors.
- Wire must be connected only to the appropriate terminals.
- Do not open the sensor housing. This will damage the sensor and invalidate the warranty.

MAINTENANCE

Our customer service representatives are available for application assistance, calibration, repair, and solutions to specific problems. Contact our Service Department before returning any equipment. In many cases, problems can be solved over the telephone.

If the sensor is not performing as it should, try to match the symptom below to the problem. If the table does not help, call Omega for further advice.

LENS CLEANING

Keep the lens clean at all times. Any foreign matter on the lens would affect measurement accuracy. Blow off loose particles (if not using the air purge accessory) with an air 'puffer'.

TROUBLESHOOTING

Symptom	Probable Cause	Solution
No output	No power to sensor	Check power supply and wiring
Inaccurate measured temperature	Target too small for sensor's field of view	Ensure the sensor's view is completely filled by the target. Position the sensor closer to the target to measure a smaller area.
	Target is a reflective metal surface	Adjust the emissivity setting to match the surface emissivity, or measure a non-reflective area, or paint or coat a measurable area of the target to make it non-reflective
	Field of view obstruction	Remove obstruction; ensure sensor has a clear view of target
	Dust or condensation on lens	Ensure lens is clean and dry. Clean gently with a soft lens cloth and water. If problem recurs, consider using an air purge collar.
	Incorrect wire connections	Check wire colour codes
Erroneous temperature (4-20 mA output)	Output temperature scale mismatch	Re-scale input temperature range on measurement instrument to match sensor

WARRANTY/DISCLAIMER

OMEGA ENGINEERING, INC. warrants this unit to be free of defects in materials and workmanship for a period of **25 months** from date of purchase. OMEGA's WARRANTY adds an additional two (2) month grace period to the normal **two (2) year product warranty** to cover handling and shipping time. This ensures that OMEGA's customers receive maximum coverage on each product.

If the unit malfunctions, it must be returned to the factory for evaluation. OMEGA's Customer Service Department will issue an Authorized Return (AR) number immediately upon phone or written request. Upon examination by OMEGA, if the unit is found to be defective, it will be repaired or replaced at no charge. OMEGA's WARRANTY does not apply to defects resulting from any action of the purchaser, including but not limited to mishandling, improper interfacing, operation outside of design limits, improper repair, or unauthorized modification. This WARRANTY is VOID if the unit shows evidence of having been tampered with or shows evidence of having been damaged as a result of excessive corrosion; or current, heat, moisture or vibration; improper specification; misapplication; misuse or other operating conditions outside of OMEGA's control. Components in which wear is not warranted, include but are not limited to contact points, fuses, and triacs.

OMEGA is pleased to offer suggestions on the use of its various products. However, OMEGA neither assumes responsibility for any omissions or errors nor assumes liability for any damages that result from the use of its products in accordance with information provided by OMEGA, either verbal or written. OMEGA warrants only that the parts manufactured by the company will be as specified and free of defects. OMEGA MAKES NO OTHER WARRANTIES OR REPRESENTATIONS OF ANY KIND WHATSOEVER, EXPRESSED OR IMPLIED, EXCEPT THAT OF TITLE, AND ALL IMPLIED WARRANTIES INCLUDING ANY WARRANTY OF MERCHANTABILITY AND FITNESS FOR A PARTICULAR PURPOSE ARE HEREBY DISCLAIMED. LIMITATION OF LIABILITY: The remedies of purchaser set forth herein are exclusive, and the total liability of OMEGA with respect to this order, whether based on contract, warranty, negligence, indemnification, strict liability or otherwise, shall not exceed the purchase price of the component upon which liability is based. In no event shall OMEGA be liable for consequential, incidental or special damages.

CONDITIONS: Equipment sold by OMEGA is not intended to be used, nor shall it be used: (1) as a "Basic Component" under 10 CFR 21 (NRC), used in or with any nuclear installation or activity; or (2) in medical applications or used on humans. Should any Product(s) be used in or with any nuclear installation or activity, medical application, used on humans, or misused in any way, OMEGA assumes no responsibility as set forth in our basic WARRANTY/DISCLAIMER language, and, additionally, purchaser will indemnify OMEGA and hold OMEGA harmless from any liability or damage whatsoever arising out of the use of the Product(s) in such a manner.

RETURN REQUESTS/INQUIRIES

Direct all warranty and repair requests/inquiries to the OMEGA Customer Service Department. BEFORE RETURNING ANY PRODUCT(S) TO OMEGA, PURCHASER MUST OBTAIN AN AUTHORIZED RETURN (AR) NUMBER FROM OMEGA'S CUSTOMER SERVICE DEPARTMENT (IN ORDER TO AVOID PROCESSING DELAYS). The assigned AR number should then be marked on the outside of the return package and on any correspondence.

The purchaser is responsible for shipping charges, freight, insurance and proper packaging to prevent breakage in transit.

FOR **WARRANTY** RETURNS, please have the following information available BEFORE contacting OMEGA:

1. Purchase Order number under which the product was PURCHASED,
2. Model and serial number of the product under warranty, and
3. Repair instructions and/or specific problems relative to the product.

FOR **NON-WARRANTY** REPAIRS, consult OMEGA for current repair charges. Have the following information available BEFORE contacting OMEGA:

1. Purchase Order number to cover the COST of the repair,
2. Model and serial number of the product, and
3. Repair instructions and/or specific problems relative to the product.

OMEGA's policy is to make running changes, not model changes, whenever an improvement is possible. This affords our customers the latest in technology and engineering.

OMEGA is a trademark of OMEGA ENGINEERING, INC.

© Copyright 2018 OMEGA ENGINEERING, INC. All rights reserved. This document may not be copied, photocopied, reproduced, translated, or reduced to any electronic medium or machine-readable form, in whole or in part, without the prior written consent of OMEGA ENGINEERING, INC.

Where Do I Find Everything I Need for Process Measurement and Control? **OMEGA...Of Course!** *Shop online at omega.com*

TEMPERATURE

- ☑ Thermocouple, RTD & Thermistor Probes, Connectors, Panels & Assemblies
- ☑ Wire: Thermocouple, RTD & Thermistor
- ☑ Calibrators & Ice Point References
- ☑ Recorders, Controllers & Process Monitors
- ☑ Infrared Pyrometers

PRESSURE, STRAIN AND FORCE

- ☑ Transducers & Strain Gages
- ☑ Load Cells & Pressure Gages
- ☑ Displacement Transducers
- ☑ Instrumentation & Accessories

FLOW/LEVEL

- ☑ Rotameters, Gas Mass Flowmeters & Flow Computers
- ☑ Air Velocity Indicators
- ☑ Turbine/Paddlewheel Systems
- ☑ Totalizers & Batch Controllers

pH/CONDUCTIVITY

- ☑ pH Electrodes, Testers & Accessories
- ☑ Benchtop/Laboratory Meters
- ☑ Controllers, Calibrators, Simulators & Pumps
- ☑ Industrial pH & Conductivity Equipment

DATA ACQUISITION

- ☑ Communications-Based Acquisition Systems
- ☑ Data Logging Systems
- ☑ Wireless Sensors, Transmitters, & Receivers
- ☑ Signal Conditioners
- ☑ Data Acquisition Software

HEATERS

- ☑ Heating Cable
- ☑ Cartridge & Strip Heaters
- ☑ Immersion & Band Heaters
- ☑ Flexible Heaters
- ☑ Laboratory Heaters

ENVIRONMENTAL MONITORING AND CONTROL

- ☑ Metering & Control Instrumentation
- ☑ Refractometers
- ☑ Pumps & Tubing
- ☑ Air, Soil & Water Monitors
- ☑ Industrial Water & Wastewater Treatment
- ☑ pH, Conductivity & Dissolved Oxygen Instruments

M5705/1018