



INTERFACE SERIES

Installation & Operation Instructions
6N1-ISO-STG

Phone: 1-888-967-5224
Website: workaci.com

GENERAL INFORMATION

The 6N1-ISO-STG series is a microprocessor controlled interface designed to provide maximum flexibility with a minimum of cost.

With a variety of standard inputs, the 6N1-ISO-STG provides the user with the ability to interface several devices to a single analog output.

The 6N1-ISO-STG is a true staging device. It can be used in retrofit applications of interfacing a two or three stage thermostat to an SCR heater. It will convert 24VAC staged signals to a proportional analog output. The 6N1-ISO-STG offers two different modes. The first mode will check inputs sequentially high(#6) to low(#1), to set output percentage. The output percentage is based on highest input pressed, and ignores others. The other mode will check the total number of inputs, to set an output percentage. The output percentage is based on total number of active inputs.

Input ranges are jumper selectable and all modes and analog outputs are DIP switch selectable. The output signal is optically isolated from the input signals. The power output terminal can be used for power if the inputs are only contact closures.

MOUNTING INSTRUCTIONS

The interface device can be mounted in any position. If circuit board slides out of snap track, a non-conductive "stop" may be required. Use only fingers to remove board from snap track. Slide out of snap track or push up against side of snap track and lift that side of the circuit board to remove. **Do not flex board or use tools.**

WIRING INSTRUCTIONS

PRECAUTIONS

- **6N1-ISO-STG is powered by 24 VAC only.**
- **Remove power before wiring. Never connect or disconnect wiring with power applied.**
- **When using a shielded cable, ground the shield only at the controller end. Grounding both ends can cause a ground loop.**
- **This device needs to have its own Isolated Transformer. This transformer cannot be connected/or shared with any other device. It is recommended you use an isolated UL-listed class 2 transformer.**
- **All wiring must comply with all local and National Electric Codes.**

Note: ACI recommends to remove the pluggable terminal blocks to terminate wires first. The terminal blocks can be removed using pliers. Once wired, rotate the terminal block 90 Degrees so they are facing upward, and insert onto pins. This eliminates any wires getting pinched by the snaptrack. See **Figure 4** (p.3).

FIGURE 1: DIMENSIONS

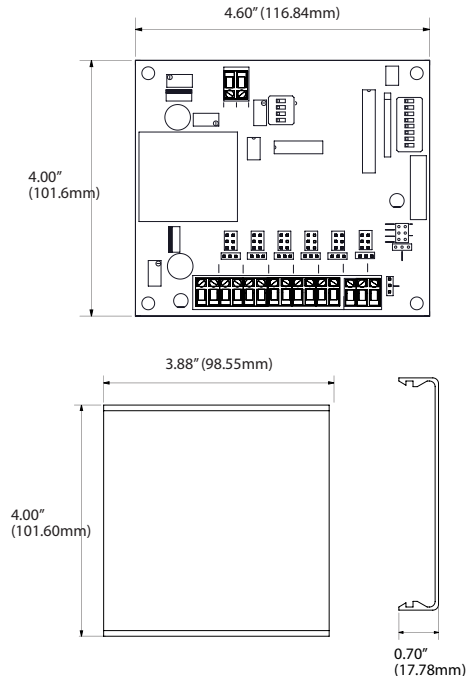

FIGURE 2: WIRING

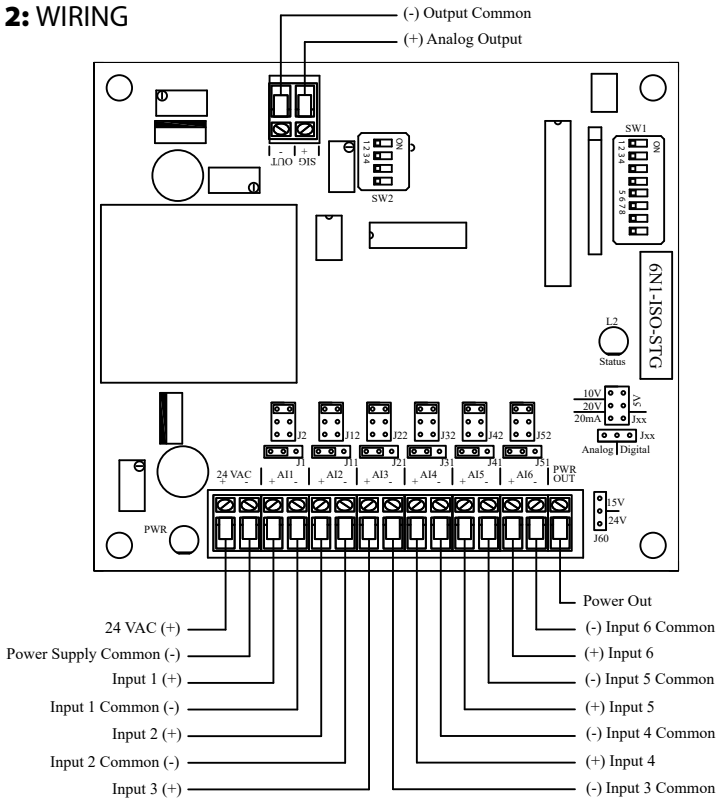

FIGURE 3: TYPICAL DIGITAL INPUTS

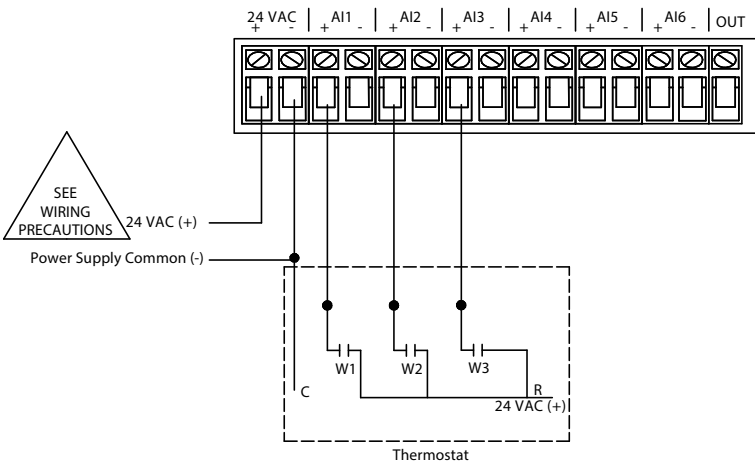
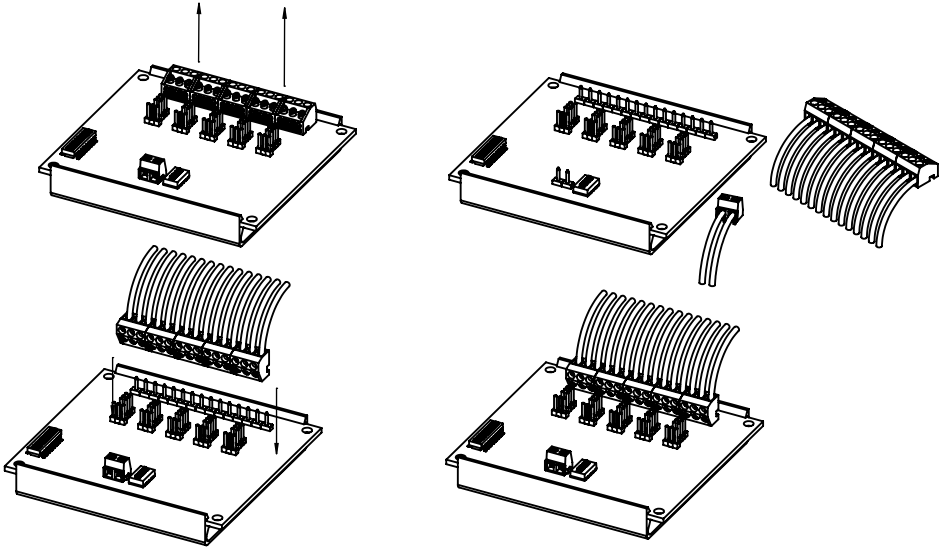

FIGURE 4: TERMINAL BLOCK INSTALLATION



Wiring Connections

Connect Input Signal Common (-) to terminals labeled (-) labeled AI1 thru AI6.

Connect Input Signal (+) to respective terminal (+) labeled AI1 thru AI6.

NOTE: The input must be 15-24VDC, or 24VAC.

Connect controlled device to SIG OUT (+) and (-).

Connect 24 VAC to terminals marked 24 VAC (+) and (-). See **Figure 2** (p.2).

Operation

The 6N1-ISO-STG can:

Fan Mode #1

Check inputs sequentially high(#6) to low(#1), to set output percentage. The output percentage is based on highest input pressed, and ignores others. This is based on the Input # priority.

Example #1: 4 Inputs used, 0-10VDC output
Activate Input #3. Output = 7.5VDC ($3/4 = 75\%$)

Example #2: 6 Inputs used, 0-10VDC output
Activate Input #4. Output = 6.6VDC ($4/6 = 66.6\%$)

Fan Mode #2

Check total number of inputs, to set output percentage. The output percentage based on

total number of inputs active.

Example #1: 4 Inputs used, 0-10VDC output
Activate Input #1 and #3. Output = 5VDC (50%)

Example #2: 4 Inputs used, 0-10VDC output
Activate Input #3. Output = 2.5VDC (25%)

Example #3: 6 Inputs used, 0-10VDC output
Activate Input #1, #4, #5, #6. Output = 6.6VDC ($4/6 = 66.6\%$)

CALIBRATION, JUMPER & DIP SWITCH SETTINGS

The 6N1-ISO-STG output is factory calibrated in all four DIP switch selectable output ranges. Do not adjust the potentiometers on the 6N1-ISO-STG as this may void any warranty.

FIGURE 5: INDIVIDUAL INPUT JUMPER SHUNT SETTINGS

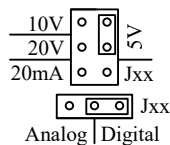

Note: Jumpers are factory set, and should not be adjusted.

Binary/Digital Mode

MODE DIP SWITCH SETTINGS – BLOCK SW1: Factory Default – FAN 2

MODE	DIPswx 1	DIPswx 2	DIPswx 3
FAN 1	OFF	OFF	OFF
FAN 2	OFF	OFF	ON

INPUTS USED DIP SWITCH SETTINGS – BLOCK SW1: Factory default – All Off

INPUTS USED	DIPswx 4	DIPswx 5	DIPswx 6
1 & 2	OFF	OFF	OFF
1 thru 3	OFF	OFF	ON
1 thru 4	OFF	ON	OFF
1 thru 5	OFF	ON	ON
All	ON	OFF	OFF

Legend: These switches are OFF If an invalid DIP switch selection is made, the status LED will blink at a rate of every two seconds.

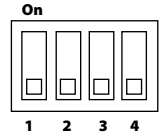

OUTPUT TYPE DIP SWITCH SETTINGS – BLOCK SW2:

OUTPUT TYPE	DIPswx 1	DIPswx 2
Voltage Out	OFF	ON
Current Out	ON	OFF

Factory default is Voltage Out

OUTPUT RANGE DIP SWITCH SETTING – BLOCK SW2:

OUTPUT RANGE	DIPswx 3	DIPswx 4
0-5V/0-20mA	ON	OFF
0-10V	OFF	ON
0-20V	OFF	OFF

Factory default is 0 -10 VDC

PRODUCT SPECIFICATIONS

Supply Voltage:	24 VAC (+/- 10%), 50/60 Hz
Supply Current:	255 mA maximum
Power Output:	24 VDC or 15 VDC (Jumper Selectable)
Power Output (Supply Current):	100 mA maximum
Input Mode (@ Impedance):	15 VDC, 24 VDC or 24 VAC +/-10% @ 100,000Ω
One Analog Signal Output (@ Impedance):	0-5 VDC @ 1000Ω 0-10 VDC @ 1000Ω 0-20 VDC @ 1000Ω 0-20 mA @ 500Ω maximum
Output Signal Accuracy:	+/- 2% of full scale
Resolution (Analog/Binary):	64 steps of resolution
Product Functions:	Stage Control
Connections:	90° Pluggable Screw Terminal Blocks
Wire Size:	16 (1.31 mm ²) to 26 AWG (0.129 mm ²)
Terminal Block Torque Rating:	0.5 Nm (Minimum); 0.6 Nm (Maximum)
Operating Temperature Range:	35 to 120°F (1.7 to 48.9°C)
Operating Humidity Range:	10 to 90% non-condensing
Storage Temperature:	-20 to 150°F (-28.9 to 65.5°C)

WARRANTY

The ACI 6N1-ISO-STG Series is covered by ACI's Two (2) Year Limited Warranty, which is located in the front of ACI'S SENSORS & TRANSMITTERS CATALOG or can be found on ACI's website: www.workaci.com.

