



# P51 SERIES GAGE PRESSURE TRANSDUCER

Installation & Operation Instructions

Phone: 1-888-967-5224  
Website: workaci.com

## GENERAL INFORMATION

The P51 Series is designed to provide excellent accuracy and reliability in commercial, industrial, and process control applications where performance is critical. The P51 Series is available in three pressure sensing types: Gage (PSIG), Sealed Gage (PSIS) and Absolute (PSIA). Gage (PSIG) sensors measure pressure relative to ambient pressure through a port that is open to the atmosphere, and are used in lower pressure applications where measurement in a vacuum is not required. Sealed sensors (PSIS) measure pressure relative to a port that is connected to a sealed perfect vacuum chamber. Sealed pressure transducers are calibrated to have 0.5 VDC, 1 VDC or 4 mA respectively at +14.5 PSIA. Absolute sensors measure pressure relative to a perfect vacuum pressure (0 PSIA), which doesn't change regardless of temperature, location or any other ambient conditions such as weather.

## OPTIONAL ACCESSORIES

### Pressure Snubber

ACI recommends the use of the A/0.25" Snubber (Water or Air/Gas) with all P51 series sensors. The use of a pressure snubber is a cost-effective solution that can extend the life of your sensor by smoothing out pressure spikes, surges and pulsations, and prevent debris from collecting in the sensor diaphragm opening. The A/0.25" Snubbers are made of 316 Stainless Steel and should be used with compatible materials.

### Syphons

The A/Syphon must be used to protect the sensor from extreme operating temperatures when the operating temperature of the steam being monitored is higher than the maximum operating temperature of the pressure sensor. There are three bend configurations available (90°, 180°, and 270°) to allow the mounting of the sensor vertically away from the main pipe.

### NEMA 4 Enclosure

ACI recommends the use of a NEMA 4 enclosure to protect the gage pressure sensor in applications where debris and moisture could contact the sensor or electrical connections. The A/GP-(xx)-NEMA 4 GP Series pressure sensor is mounted in a NEMA 4 Rated, steel enclosure with one 1/2" conduit knockout. A 1/4" male NPT Stainless Steel fitting is provided for installation to your pipe, tank, or reservoir.

**FIGURE 1: PRODUCT DIMENSIONS**  
**Packard**

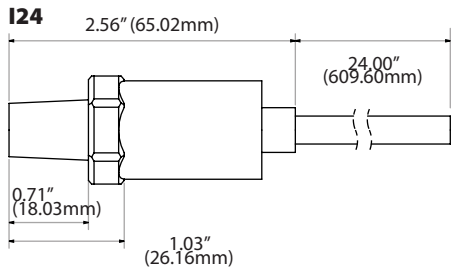
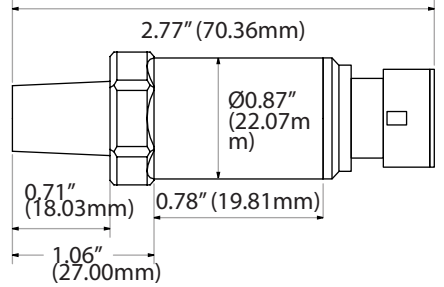

**7/8" HEX**

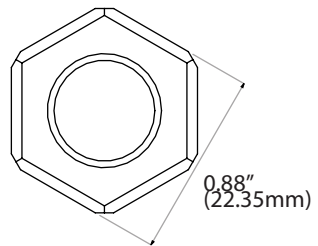

## MEDIA COMPATIBILITY

The bulk micro-machined transducer features a stainless steel diaphragm with welded construction that contains no O-rings, which makes them compatible with any gas or liquid that's compatible with 304L or 316L stainless steel. Some compatible gasses and liquids include refrigerants, glycol, motor oil, diesel, hydraulic fluid, brake fluid, water, waste water, hydrogen, nitrogen and air.

## Installation

### LOCATION

Install the sensor in a location where it will not be exposed to extreme temperatures, vibration or shock. Install the pressure sensor above or on the side of pipes, in a location where liquid will not drip on the unit. Condensation can potentially build up and run down the harness; position the unit and harness so water does not pool on the back of the sensor. Do not install the sensor at the end of a long run of pipe.

### CONNECTION

The P51 series sensor is available with multiple external thread sizes, see the Datasheet chart for more details. Standard pipe fittings and installation procedures should be used during installation. Install pipe tape, thread sealant or other suitable pipe compound when connecting the sensor to the pressure source or any of the accessories. For pressure ranges more than 500 PSI (3447.4 kPa), we recommend the use of a sealant such as Loctite Hydraulic Sealant. Do not use excessive amounts of sealant or you might block the pressure going into the transducer. Install the device using a wrench on the hex flats provided. Do not use a strap wrench on the body. When installing the sensor, the torque limit will vary, see the Torque Limits Table for more detail. Do Not over tighten. Overtightening metal fittings may cause a slight zero shift. The use of plastic fittings typically results in no noticeable zero shift. The torquing effect does not appreciably affect linearity or sensitivity. In liquid pressure monitoring applications, air present in the lines will cause erratic readings, use bleed fittings to bleed off any air that has been trapped before transducer installation.

## WIRING INSTRUCTIONS

The supply voltage and current required will vary per unit, see the General Specifications Table for more details. If you've selected a Packard connector make the proper connections to the harness, then install the P51 Sensor onto the harness.

**Note:** Be careful not to kink the vent tube if cutting the 24" PVC wire down or removing all together. Kinking the clear tube will affect the reference pressure on all PSIG Series Transducers.

### 4-20 OUTPUT CONNECTIONS

Connect the Power lead (Red) to the plus terminal of the supply voltage. Connect the Return lead (White)

**FIGURE 2: ASSEMBLY**

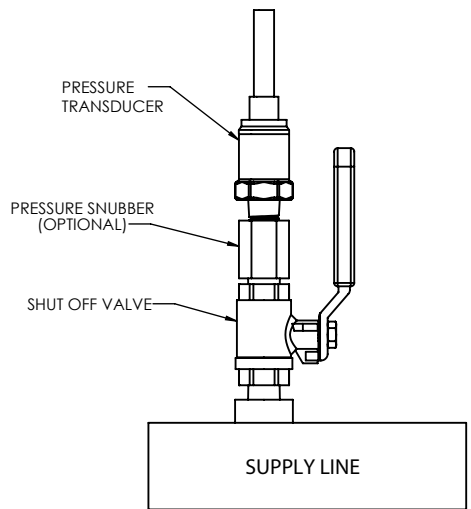

**TABLE 1: TORQUE LIMITS**

Straight Thread w/O-Ring:	Recommended Torque
High Pressure >750 PSI (5171.1 kPa)	300 in lb (33.9 Nm)
All Other Ports Except Port Types U, Y	150 in lb (16.95 Nm)
Port Types U, Y	120 in lb (13.6 Nm)

## WIRING INSTRUCTIONS (Continued)

to the plus terminal of the current measuring device (controller). Connect the minus terminal of the current measuring device to the minus terminal of the supply voltage, and the Shield Wire (Green) should be connected to the system or earth ground. See **Figure 3**, Current Wiring diagram.

**Note:** If the harness has a black wire, do not use it.

**FIGURE 3: CURRENT WIRING DIAGRAM**

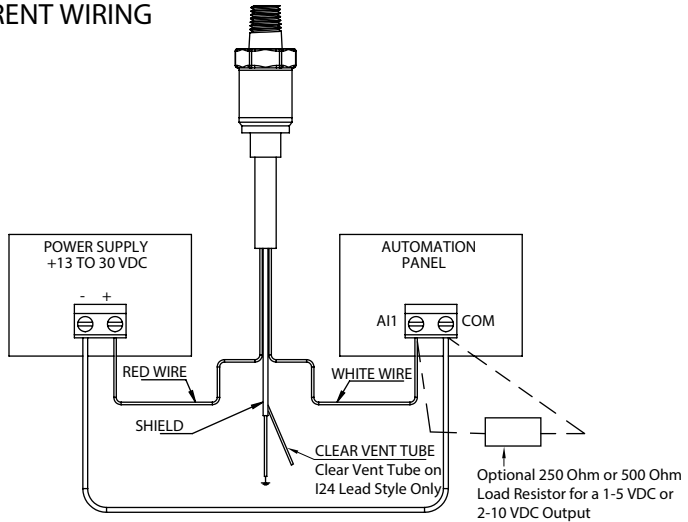

## VOLTAGE OUTPUT CONNECTIONS

Connect the Power lead (Red) to the plus terminal of the supply voltage. Connect the Ground lead (Black) and the minus terminal of the supply voltage to the minus input of your voltage measurement equipment. Connect the Vout lead (White) to the plus input of your voltage measurement equipment, and the Shield Wire should be connected to the system or earth ground. See **Figure 4**, Voltage Wiring diagram.

**FIGURE 4: VOLTAGE WIRING DIAGRAM**

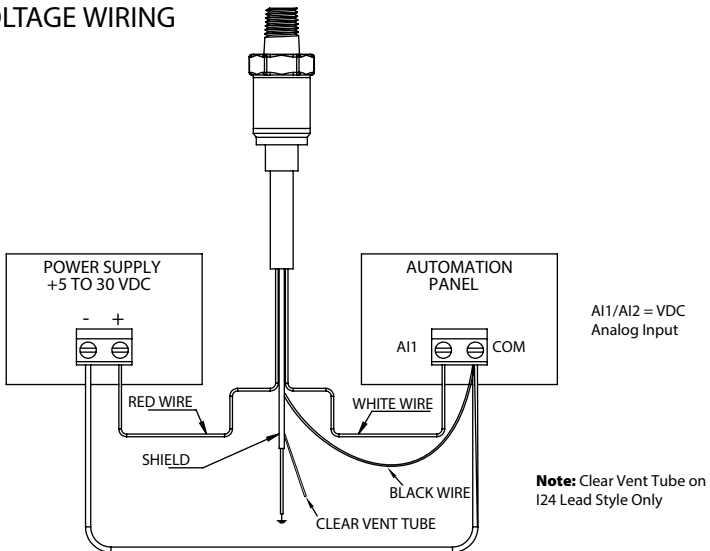

# TROUBLESHOOTING

PROBLEM	SOLUTION(S)
<b>No Output or Output Signal Reading Low:</b>	<ul style="list-style-type: none"><li>• Confirm the DC supply voltage is:<ul style="list-style-type: none"><li>• 0.5 to 4.5 VDC Output Only: 5.00 VDC +/- 0.500 VDC.</li><li>• 4 to 20 mA and 1 to 5 VDC Outputs Only: +8 to 30 VDC (No Load).</li><li>• 4-20 mA Output: 250 Ohm Load: +13 to 30 VDC   500 Ohm Load: +18 to 30 VDC.</li></ul></li></ul>
<b>Output Signal is Inaccurate:</b>	<ul style="list-style-type: none"><li>• Disconnect the sensor from the line to ensure No debris or sediment is blocking the inlet port of the transducer.</li><li>• If a clear vent tube is present (I24 models only), confirm that the tube is not kinked or has been removed.</li><li>• Determine that the proper output is being transmitted based on the predetermined span. Measure the output of the transmitter with a handheld multimeter and compare the measured output to calculate output.</li></ul>

## W.E.E.E. DIRECTIVE

At the end of their useful life the packaging and product should be disposed of via a suitable recycling centre. Do not dispose of with household waste. Do not burn.

## WARRANTY

The P51 Series Pressure transducers are covered by ACI's Two (2) Year Limited Warranty. The warranty can be found in the front of ACI's Sensors & Transmitters catalog, as well as on ACI's website, [www.workaci.com](http://www.workaci.com).

# PRODUCT SPECIFICATIONS

SENSOR NON-SPECIFIC INFORMATION	
<b>Supply Voltage:</b>	<b>0.5 to 4.5 VDC Output Only:</b> 5.00 VDC +/- 0.500 VDC <b>4 to 20 mA and 1 to 5 VDC Outputs Only:</b> +8 to 30 VDC (No Load) <b>4-20 mA Output:</b> 250 Ohm Load: +13 to 30 VDC   500 Ohm Load: +18 to 30 VDC
<b>Supply Current:</b>	<b>4 to 20 mA:</b> 25 mA minimum   0.5 to 4.5 VDC: < 3 mA   1 to 5 VDC: < 5 mA
<b>Output Signal:</b>	4 to 20 mA (2-Wire, Loop Powered); 0.5 to 4.5 VDC (3-Wires); 1 to 5 VDC (3-Wires)
<b>Proof Pressure   Burst Pressure:</b>	<b>15 to 300 PSIG/PSIS:</b> 3x FS   15 to 300 PSIG/PSIS: 3x FS <b>15 to 3000 PSIA:</b> 3x FS   <b>15 to 3000 PSIA:</b> 10x FS or 15,000 PSI (whichever is less) <b>500 to 750 PSIS:</b> 3x FS   500 to 750 PSIS: 3x FS <b>1000 to 3000 PSIS:</b> 3x FS   1000 to 3000 PSIS: 10x FS or 20,000 PSI (whichever is less)
<b>Accuracy @ 22°C (71.6°F):</b> *Accuracy includes Hysteresis, Repeatability, and Non-linearity (BFSL)	<b>15 to 60 PSIG/PSIS:</b> < +/- 1.0% FS; <b>75 to 300 PSIG/PSIS:</b> < +/- 0.5% FS <b>500 to 750 PSIS<sup>2</sup>:</b> < +/- 0.5% FS; <b>1000 to 5000 PSIS<sup>2</sup>:</b> < +/- 1% FS <b>15 to 200 PSIA:</b> < +/- 0.5% FS; <b>300 to 750 PSIA:</b> < +/- 0.5% FS; <b>1000 to 3000 PSIA:</b> < +/- 1% FS
<b>Thermal Error (-40° to 105°C):</b> *Additional error over temperature range	<b>15 to 60 PSIG/PSIS:</b> < +/- 1.0% FS; <b>75 to 300 PSIG/PSIS:</b> < +/- 0.5% FS <b>500 to 750 PSIS:</b> < +/- 0.5% FS; <b>1000 to 3000 PSIS:</b> < +/- 1% FS <b>15 to 200 PSIA:</b> < +/- 0.5% FS; <b>300 to 750 PSIA:</b> < +/- 0.5% FS; <b>1000 to 3000 PSIA:</b> < +/- 1% FS
<b>Stability (250 Hours @ 225°F (125°C)):</b>	+/- 0.03% FS @ 0 PSIG; +/- 0.12% FS @ 1000 PSIG
<b>Operating   Storage Temperature Ranges:</b>	-40 to 221°F (-40 to 105°C)   -40 to 176°F (-40 to 80°C)
<b>Process Fitting Material   Thread Size:</b>	304L or 316L Stainless Steel   See Datasheet for more details
<b>Operating Humidity Range:</b>	0 to 95% RH, non-condensing
<b>Media Types:</b>	Any gas or liquid compatible with 304L or 316L Stainless Steel
<b>Recommended Torque Specifications:</b>	All Ports except "U" and "Y": 150 lbs-in (16.95 Nm); Ports "U" and "Y": 120 lbs-in (13.56 Nm)
<b>Wiring Connections:</b>	Packard Connector (Cables ordered separately per "Ordering Grid" on back of data sheet) <b>"-124" (24 Lead Length):</b> PVC Jacketed Cable 18 (0.823 mm <sup>2</sup> ) or 24 AWG (0.2047 mm <sup>2</sup> ) <b>"-MD" Din 43650:</b> Hirschman® Connector with 90° Mating Connector

**Note 1:** PSIS transducers are not vented to atmosphere, but are calibrated to have 0.5 VDC, 1 VDC or 4 mA at +14.5 PSIG

