

1 YEAR
WARRANTY



RoHS



Ω OMEGA™

User's Guide



Shop online at
omega.com

e-mail: info@omega.com
For latest product manuals:
www.omegamanual.info

ISO 9001
CERTIFIED
CORPORATE QUALITY

ISO 9001
CERTIFIED
CORPORATE QUALITY

NORWALK, CT MANCHESTER, UK

FMA1700A & FMA1800A Mass Flowmeter



omega.com info@omega.com
Servicing North America:

U.S.A.

Headquarters:

Omega Engineering, Inc.

Toll-Free: 1-800-826-6342 (USA & Canada only)

Customer Service: 1-800-622-2378 (USA & Canada only)

Engineering Service: 1-800-872-9436 (USA & Canada only)

Tel: (203) 359-1660

Fax: (203) 359-7700

e-mail: info@omega.com

For Other Locations Visit omega.com/worldwide

 **CAUTION:**

This product is not intended to be used in life support applications!

 **CAUTION:**

Some of the IC devices used in the instrument are static-sensitive and may be damaged by improper handling. When adjusting or servicing the device, use of a grounded wrist strap is recommended to prevent inadvertent damage to the integral solid-state circuitry.

 **CAUTION:**

K-Factors at best are only an approximation.
K-Factors should not be used in applications that require accuracy better than +/- 5 to 10%.

TABLE OF CONTENTS

1. UNPACKING THE FMA1700A/1800A MASS FLOW METER	1
1.1 Inspect Package for External Damage.....	1
1.2 Unpack the Mass Flow Meter.....	1
1.3 Returning Merchandise for Repair.....	1
2. INSTALLATION	1
2.1 Primary Gas Connections.....	1
2.2 Electrical Connections.....	2
2.3.1 Remote LCD Readouts.....	4
2.3.2 Panel Mounting Readouts.....	4
3. PRINCIPLE OF OPERATION	5
4. SPECIFICATIONS	6
4.1 CE Compliance.....	7
5. OPERATING INSTRUCTIONS	9
5.1 Preparation and Warm Up.....	9
5.2 Flow Signal Output Readings.....	9
5.3 Swamping Condition.....	10
6. MAINTENANCE	10
6.1 Introduction.....	10
6.2 Flow Path Cleaning.....	10
6.2.1 Restrictor Flow Element (RFE).....	10
6.2.2 FMA1700A/1800A Series Max. Flow 10 L/min.....	11
7. CALIBRATION PROCEDURES	12
7.1 Flow Calibration.....	12
7.2 Calibration of FMA1700A/1800A Mass Flow Meters.....	14
7.2.1 Connections and Initial Warm Up.....	14
7.2.2 ZERO Adjustment.....	14
7.2.3 SPAN Adjustment.....	14
7.3 Linearity Adjustment.....	15
7.3.1 Connections and Initial Warm Up.....	15
7.3.2 ZERO Adjustment.....	15
7.3.3 25% Flow Adjustment (using R33 potentiometer).....	15
7.3.4 10% Flow Adjustment.....	16
7.3.5 25% Flow Adjustment (using R52 potentiometer).....	16

7.3.6	50% Flow Adjustment.....	16
7.3.7	75% Flow Adjustment.....	16
7.3.8	100% Flow Adjustment.....	16
7.4	LCD Display Scaling.....	16
7.4.1	Access LCD Display Circuit.....	17
7.4.2	Adjust Scaling.....	17
7.4.3	Change Decimal Point.....	17
8.	TROUBLESHOOTING.....	17
8.1	Common Conditions.....	17
8.2	Troubleshooting Guide.....	18
8.3	Technical Assistance.....	22
9.	CALIBRATION CONVERSIONS FROM REFERENCE GASES.....	23
APPENDIX 1	COMPONENT DIAGRAM.....	24
APPENDIX 2	GAS FACTOR TABLE (“K” FACTORS).....	25
APPENDIX 3	DIMENSIONAL DRAWINGS.....	29
	PARTS OF THE FLOW METER.....	31
APPENDIX 4	WARRANTY.....	34

1. UNPACKING THE FMA1700A/1800A MASS FLOW METER

1.1 Inspect Package for External Damage

Remove the Packing List and verify that you have received all equipment. If you have any questions about the shipment, please call the OMEGA® Customer Service Department at 1-800-622-2378 or (203) 359-1660.

Your FMA1700A/1800A Mass Flow Meter was carefully packed in a sturdy cardboard carton, with anti-static cushioning materials to withstand shipping shock. Upon receipt, inspect the package for possible external damage. In case of external damage to the package contact the shipping company immediately.

1.2 Unpack the Mass Flow Meter



CAUTION: Some of the IC devices used in the FMA1700A & FMA1800A are Electro Static Discharge (ESD) sensitive and may be damaged by improper handling. When wiring interface connector, adjusting or servicing the meter, use of a grounded ESD protection wrist strap is required to prevent inadvertent damage to the CMOS integral solid state circuitry. When 9 pin Interface D-connector is not used do not remove factory installed ESD protection cover.

Open the carton carefully from the top and inspect for any sign of concealed shipping damage. In addition to contacting the shipping carrier please forward a copy of any damage report to OMEGA® directly.

When unpacking the instrument please make sure that you have all the items indicated on the Packing List. Please report any shortages promptly.

1.3 Returning Merchandise for Repair

Please contact an OMEGA® customer service representative and request a **Return Authorization Number (AR)**.

It is mandatory that any equipment returned for servicing be purged and neutralized of any dangerous contents including but not limited to toxic, bacterially infectious, corrosive or radioactive substances. No work shall be performed on a returned product unless the customer submits a fully executed, signed SAFETY CERTIFICATE. Please request form from the Service Manager.

2. INSTALLATION

2.1 Primary Gas Connections

Please note that the FMA1700A/1800A Mass Flow Meter will not operate with liquids. Only clean gases are allowed to be introduced into the instrument. If gases are contaminated they must be filtered to prevent the introduction of impediments into the sensor.



CAUTION: IT IS THE USERS RESPONSIBILITY TO DETERMINE IF THE INSTRUMENT IS APPROPRIATE FOR THEIR OXYGEN APPLICATION, AND FOR SPECIFYING O₂ CLEANING SERVICE IF REQUIRED. OMEGA IS NOT LIABLE FOR ANY DAMAGE OR PERSONAL INJURY, WHATSOEVER, RESULTING FROM THE USE OF THIS INSTRUMENT FOR OXYGEN GAS.

Attitude sensitivity of the Mass Flow Meter is ± 15 . This means that the gas flow path of the Flow Meter must be horizontal within those stated limits. Should there be need for a different orientation of the meter, re-calibration may be necessary. It is also preferable to install the FMA1700A/1800A transducer in a stable environment, free of frequent and sudden temperature changes, high moisture, and drafts.

Prior to connecting gas lines inspect all parts of the piping system including ferules and fittings for dust or other contaminant's.

Be sure to observe the direction of gas flow as indicated by the arrow on the front of the meter when connecting the gas system to be monitored.

Insert tubing into the compression fittings (except FMA1700A/1800A Series Max Flow 1000 L/min) until the ends of the properly sized tubings home flush against the shoulders of the fittings. Compression fittings are to be tightened according to the manufacturer's instructions to one and one quarter turns. Avoid over tightening which will seriously damage the Restrictor Flow Elements (RFE's)!

Using a Helium Leak Detector or other equivalent method perform a thorough leak test of the entire system. (All FMA1700A/1800A are checked prior to shipment for leakage within stated limits. See specifications in this manual.)

2.2 Electrical Connections



CAUTION: Some of the IC devices used in the FMA1700A & FMA1800A are Electro Static Discharge (ESD) sensitive and may be damaged by improper handling. When wiring interface connector, adjusting or servicing the meter, use of a grounded ESD protection wrist strap is required to prevent inadvertent damage to the CMOS integral solid state circuitry. When 9 pin interface D-connector is not used do not remove factory installed ESD protection cover.



CAUTION: WIRING THE FMA1700A & FMA1800A METER WITH THE POWER ON MAY RESULT IN INTERNAL DAMAGE! PLEASE MAKE ALL WIRING CONNECTIONS BEFORE SWITCHING ON THE POWER.

All FMA1700A & FMA1800A models require power supplies with nominal current rating of at least 200 mA. The operating power input is supplied via the DC power jack or the 9-pin "D" connector located at the side of the flow transducer enclosure. On FMA1700A & FMA1800A's purchased without an LCD readout, a readout panel meter, digital multimeter, or other equivalent device is required to observe the flow signal.

The FMA1700A & FMA1800A flow meters have universal power input and can be used with any power supply voltage between +12 and +26 Vdc.



CAUTION: BEFORE CONNECTING POWER SUPPLY CHECK YOUR METER SERIAL NUMBER AND POWER SUPPLY REQUIREMENTS LABEL LOCATED ON THE FLOW METER BACK COVER. DO NOT CONNECT POWER SUPPLY WITH VOLTAGE ABOVE 26 VDC. EXCEEDING SPECIFIED MAXIMUM POWER SUPPLY VOLTAGE LIMIT MAY RESULT IN DEVICE PERMANENT DAMAGE.

PIN	FUNCTION
1	Remote LCD display signal
2	0 to 5 VDC output indication
3	0 to 5 VDC common
4	Power supply, positive
5	Power supply, common
6	Remote LCD display reference (unassigned)
7	4 to 20 mA output indication self-powered (sourcing type, non-isolated)
8	4 to 20 mA common (return)
9	4 to 20 mA common (return)

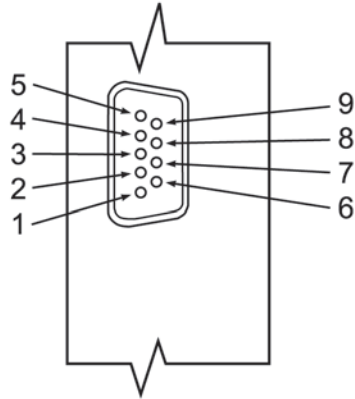

FIGURE 2.a - 9-PIN "D" CONNECTOR PINOUTS FOR FMA1700A/1800A TRANSDUCER



Important notes:

In general, "D" Connector numbering patterns are standardized. There are, however, some connectors with nonconforming patterns and the numbering sequence on your mating connector may or may not coincide with the numbering sequence shown in our pin configuration table above. It is imperative that you match the appropriate wires in accordance with the correct sequence regardless of the particular numbers displayed on your mating connector.

Make sure power is OFF when connecting or disconnecting any cables in the system.

When connecting power to the FMA1700A/1800A mass flow meter via the DC power jack, do not connect any power supply to the 9-pin "D" Connector. The DC power jack has a center positive polarity.

When battery use is required to power the FMA1700A/1800A, use only the optional battery and accompanying charger available from OMEGA®.

The power input is protected by 300 mA M (medium time-lag) resettable fuse. If a shorting condition or polarity reversal occurs, the fuse will cut power to the flow transducer circuit. Disconnect the power to the unit, remove the faulty condition, and reconnect the power. The fuse will reset once the faulty condition has been removed.



CAUTION: Resettable fuse will not protect meter if power supply voltage exceeds maximum voltage specified for particular model.

In order to operate flow meter within the specification the cable length for analog 0-5 Vdc output and remote LCD display may not exceed 9.5 feet (3 meters).

Use of the FMA1700A/1800A flow transducer in a manner other than that specified in this manual or in writing from OMEGA®, may impair the protection provided by the equipment.

2.3.1 Remote LCD Readouts

FMA1700A/1800A Mass Flow Meters are available with optional remote reading LCD displays supplied with a three foot long wire to accommodate most applications. This configuration includes the upper block element which serves as the LCD readout mounting. Special lengths of remote extension wiring (up to 9.5 feet [3 meters]) are available on request.

2.3.2 Panel Mounting Readouts

Another option for the FMA1700A/1800A Mass Flow Meter is the Panel Mounting Remote Readout. In this configuration the LCD readout is supplied with a three foot long extension wire, and no aluminum housing around the LCD. The LCD readout for panel mounting includes a bezel with two plastic screws which conveniently fit into a rectangular cut-out for panel mounting (see Figure 2.b).

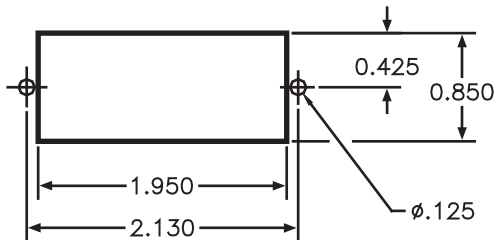

FIGURE 2.b - CUTOUT DIMENSIONS FOR LCD PANEL MOUNTING

3. PRINCIPLE OF OPERATION

The stream of gas entering the Mass Flow transducer is split by shunting a small portion of the flow through a capillary stainless steel sensor tube. The remainder of the gas flows through the primary flow conduit. The geometry of the primary conduit and the sensor tube are designed to ensure laminar flow in each branch. According to principles of fluid dynamics the flow rates of a gas in the two laminar flow conduits are proportional to one another. Therefore, the flow rates measured in the sensor tube are directly proportional to the total flow through the transducer.

In order to sense the flow in the sensor tube, heat flux is introduced at two sections of the sensor tube by means of precision wound heater-sensor coils. Heat is transferred through the thin wall of the sensor tube to the gas flowing inside. As gas flow takes place heat is carried by the gas stream from the upstream coil to the downstream coil windings. The resultant temperature dependent resistance differential is detected by the electronic control circuit. The measured gradient at the sensor windings is linearly proportional to the instantaneous rate of flow taking place.

An output signal is generated that is a function of the amount of heat carried by the gases to indicate mass-molecular based flow rates.

4. SPECIFICATIONS

FLOW MEDIUM: Please note that FMA1700A/1800A Series Max Flow 10, 50, 100, 200, 500 and 1000 L/min Mass Flow Meters are designed to work with clean gases only. Never try to meter or control flow rates of liquids with any FMA1700A/1800A.

CALIBRATIONS: Performed at standard conditions [14.7 psia (1.01 bars) and 70 °F (21.1 °C)] unless otherwise requested or stated.

ENVIRONMENTAL (per IEC 664): Installation Level II; Pollution Degree II.

ACCURACY: FMA1700A/1800A Series Max Flow 10, 50 and 100 L/min $\pm 1.0\%$ F.S.
FMA1700A/1800A Series Max Flow 200, 500 and 1000 L/min. $\pm 1.5\%$ F.S.

REPEATABILITY: $\pm 0.25\%$ of full scale.

TEMPERATURE COEFFICIENT: 0.15% of full scale/ °C.

PRESSURE COEFFICIENT: 0.01% of full scale/psi (0.07 bar).

RESPONSE TIME: 800 ms time constant; approximately 2 seconds to within $\pm 2\%$ of set flow rate for 25% to 100% of full scale flow rate.

GAS PRESSURE: 1000 psig (69 bars) FMA1700A/1800A Series Max Flow 10, 50 and 100; 500 psig (34.5 bars) FMA1700A/1800A Series Max Flow 200, 500 and 1000 L/min. Optimum pressure is 20 psig (1.4 bars).

GAS AND AMBIENT TEMPERATURE: 32 °F to 122 °F (0 °C to 50 °C).
14 °F to 122 °F (-10 °C to 50 °C) - Dry gases only.

RELATIVE GAS HUMIDITY: Up to 70%.

LEAK INTEGRITY: 1×10^{-9} sccs He max. to the outside environment.

ATTITUDE SENSITIVITY: No greater than ± 15 degree rotation from horizontal. Standard calibration is in horizontal position.

OUTPUT SIGNALS: Linear 0-5 VDC (1000 Ω minimum load impedance) and 4-20 mA self-powered sourcing type, non-isolated, (0-500 Ω loop resistance); 20 mV peak to peak max noise.

Contact Omega® for optional RS232 or RS485 interfaces.

TRANSDUCER INPUT POWER:

FMA1700A & FMA1800A models with universal power input between +12 and +25 VDC, 200 mA maximum;

Power input is protected by a 300 mA M (medium time-lag) resettable fuse, and a rectifier diode for polarity protection.

WETTED MATERIALS:

FMA1700A/1800A Series Max Flow 10, 50, 100, 200, 500 and 1000 L/min: Anodized aluminum, brass, and 316 stainless steel with FKM O-rings seals; BUNA, EPR or Perfluoroelastomer O-rings are optional.

FMA1700A/1800A Series Max Flow 10, 50, 100, 200, 500 and 1000 L/min: 316 stainless steel with FKM O-rings seals; BUNA, EPR or Perfluoroelastomer O-rings are optional.

OMEGA® makes no expressed or implied guarantees of corrosion resistance of mass flow meters as pertains to different flow media reacting with components of meters. It is the customers' sole responsibility to select the model suitable for a particular gas based on the fluid contacting (wetted) materials offered in the different models.

INLET AND OUTLET CONNECTIONS:

FMA1700A/1800A Series Max. Flow 10 and 50 L/min: 1/4" compression fittings.
Optional: 6mm compression, 1/4" VCR®, 3/8" or 1/8" compression fittings (Max. Flow 10).
FMA1700A/1800A Series Max. Flow 100 and 200 L/min: 3/8" compression fittings.
FMA1700A/1800A Series Max. Flow 500 L/min: 1/2" compression fittings.
FMA1700A/1800A Series Max. Flow 1000 L/min: 3/4" FNPT fittings or 3/4" compression fittings.

LCD DISPLAY: 3½ digit LCD (maximum viewable digits "1999"), 0.5 inch high characters. On FMA1700A/1800A aluminum or stainless steel models the LCD display is built into the upper block element and may be tilted over 90 degrees for optimal viewing comfort. Remote or panel mounting remote reading is optional.

Standard readings are in direct engineering units for the given gas and flow rate (i.e. liters/minute [lpm], standard cubic centimeters/minute [sccm], standard cubic feet/hour [scfh], etc.). 0 to 100% LCD calibration scaling is available upon request at time of order. Contact OMEGA® when non-standard display settings are desired.

TRANSDUCER INTERFACE CABLE: Optional shielded cable is available mating to the FMA1700A/1800A transducer 9-pin "D" connector. In order to operate flow meter within the specification the cable length for analog 0-5 Vdc output and remote LCD display may not exceed 9.5 feet (3 meters).

4.1 CE Compliance

Any model FMA1700A/1800A bearing a CE marking on it, is in compliance with the below stated test standards currently accepted.

EMC Compliance with 89/336/EEC as amended; Emission Standard: EN 55011:1991, Group 1, Class B Immunity Standard: EN 55082-2:1992.

FLOW RANGES

**TABLE I FMA1700A/1800A
SERIES MAX FLOW 10 L/min
LOW FLOW MASS FLOW METER***

CODE	mL/min [N ₂]
02	0 to 10
04	0 to 20
06	0 to 50
08	0 to 100
10	0 to 200
12	0 to 500
CODE	L/min [N ₂]
14	0 to 1
16	0 to 2
18	0 to 5
20	0 to 10

**TABLE II FMA1700A/1800A
SERIES MAX FLOW 50 L/min
MEDIUM FLOW MASS FLOW METER***

CODE	L/min [N ₂]
23	15
24	20
26	30
27	40
28	50

**TABLE III FMA1700A/1800A
SERIES MAX FLOW 100 L/min
HIGH FLOW MASS FLOW METER***

CODE	L/min [N ₂]
40	60
41	80
42	100
43	200
44	500
45	1000

* Flow rates are stated for Nitrogen at STP conditions [i.e. 70 °F (21.1 °C) at 1 atm].

For other gases use the K factor as a multiplier from APPENDIX 2.

TABLE IV PRESSURE DROPS

MAXIMUM FLOW RATE SERIES	FLOW RATE [liters/min N ₂]	MAXIMUM PRESSURE DROP		
		[mm H ₂ O]	[psid]	[mbar]
10 L/min	up to 10	58	0.083	5.7
50 L/min	15	63	0.09	6.4
	20	300	0.44	30
	30	800	1.18	81
	40	1480	2.18	150
	50	2200	3.23	223
100 L/min	60	3100	4.56	314
	100	5500	8.08	557
200 L/min	200	2720	4.0	280
500 L/min	500	3400	5.0	340
1000 L/min	1000	6120	9.0	620

5. OPERATING INSTRUCTIONS

5.1 Preparation and Warm Up

It is assumed that the Mass Flow Meter has been correctly installed and thoroughly leak tested as described in section 2. Make sure the flow source is OFF. Apply power to the unit by plugging the power supply line into the DC power jack (or 9-pin 'D' connector) on the side of the meter. Allow the Mass Flow Meter to warm-up for a minimum of 15 minutes.



SUPPLYING DC POWER TO THE POWER JACK AND THE “D” CONNECTOR AT THE SAME TIME WILL DAMAGE THE METER. DC POWER JACK POLARITY IS CENTER POSITIVE.

During initial powering of the FMA1700A/1800A transducer, the flow output signal will be indicating a higher than usual output. This is indication that the FMA1700A/1800A transducer has not yet attained its minimum operating temperature. This condition will automatically cancel within a few minutes and the transducer should eventually zero. If after the 15 minutes warm-up period, the display still indicates a reading of less than $\pm 3.0\%$ of F.S., readjust the ZERO potentiometer [R34] through the access hole. Before zero adjustment it is good practice to temporarily disconnect the gas source, to ensure that no seepage or leak occurs in to the meter.



ADJUSTING ZERO READING MORE THAN $\pm 3.0\%$ F.S. FROM THE FACTORY SETTINGS MAY AFFECT DEVICE CALIBRATION ACCURACY. IF SUCH ADJUSTMENT IS REQUIRED IT IS RECOMMENDED TO PERFORM METER RECALIBRATION TO PRESERVE DEVICE ACCURACY.

5.2 Flow Signal Output Readings

Initiate a controlled gas flow after warm up. The flow signal output can be viewed either on the LCD display, remote panel meter, digital multimeter, or other display device.

If an LCD display has been supplied with the FMA1700A/1800A, the observed reading is in direct engineering units (0 to 100% indication is optional).

Analog output flow signals of 0 to 5 VDC and 4 to 20 mA are attained at the appropriate pins of the 9-pin “D” connector (see Figure 2.a) on the side of the FMA1700A/1800A transducer.

Meter signal output is linearly proportional to the mass molecular flow rate of the gas being metered. By default calibration is done against 0 to 5 VDC output signal. If 4-20 mA output signal is used for flow indication on the FMA1700A/1800A, which was calibrated against 0 to 5 VDC, the total uncertainty of the reading may be in the range of $\pm 2.5\%$ of full scale. Optional calibration for 4-20 mA output signal is available upon request at time of order. The full scale range and gas for which your meter has been calibrated are shown on the flow transducers front label.

5.3 Swamping Condition

If a flow of more than 10% above the maximum flow rate of the Mass Flow Meter is taking place, a condition known as “swamping” may occur. Readings of a “swamped” meter cannot be assumed to be either accurate or linear. Flow must be restored to below 110% of maximum meter range. Once flow rates are lowered to within calibrated range, the swamping condition will end. Operation of the meter above 110% of maximum calibrated flow may increase recovery time.

6. MAINTENANCE

6.1 Introduction

It is important that the Mass Flow Meter/Controller is used with clean, filtered gases only. Liquids may not be metered. Since the RTD sensor consists, in part, of a small capillary stainless steel tube, it is prone to occlusion due to impediments or gas crystallization. Other flow passages are also easily obstructed. Therefore, great care must be exercised to avoid the introduction of any potential flow impediment. To protect the instrument a 50 micron (FMA1700A/1800A Series Max Flow 10 L/min) or 60 micron (FMA1700A/1800A Series Max Flow 100 and 200 L/min) filter is built into the inlet of the flow transducer. The filter screen and the flow paths may require occasional cleaning as described below. There is no other recommended maintenance required. It is good practice, however, to keep the meter away from vibration, hot or corrosive environments and excessive RF or magnetic interference.

If periodic calibrations are required they should be performed by qualified personnel and calibrating instruments, as described in section 7. It is recommended that units are returned to OMEGA® for repair service and calibration.



CAUTION: TO PROTECT SERVICING PERSONNEL IT IS MANDATORY THAT ANY INSTRUMENT BEING SERVICED IS COMPLETELY PURGED AND NEUTRALIZED OF TOXIC, BACTERIOLOGICALLY INFECTED, CORROSIVE OR RADIOACTIVE CONTENTS.

6.2 Flow Path Cleaning

Before attempting any disassembly of the unit for cleaning, try inspecting the flow paths by looking into the inlet and outlet ends of the meter for any debris that may be clogging the flow through the meter. Remove debris as necessary. If the flow path is not unclogged, then proceed with steps below.

Do not attempt to disassemble the sensor. If blockage of the sensor tube is not alleviated by flushing through with cleaning fluids, please return meter for servicing.



NOTE: DISASSEMBLY MAY COMPROMISE CURRENT CALIBRATION.

6.2.1 Restrictor Flow Element (RFE)

The Restrictor Flow Element (RFE) is a precision flow divider inside the transducer, which splits the inlet gas flow by a preset amount to the sensor and main flow paths. The particular RFE used in a given Mass Flow Meter depends on the gas and flow range of the instrument.

6.2.2 FMA1700A/1800A Series Max Flow 10 L/min models

1. Unscrew both the inlet & outlet compression fittings from the meter using an 11/16" open box wrench.
2. Unscrew the RFE sub ass'y from the unit's inlet side using a flat 1/2" wide screwdriver.
3. Push a pin/ screw driver dia 3/32-1/8" thru the adapter's holes, then unscrew a retaining nut using a 1/4" Allan wrench.

The 50 micron filter screen will now become accessible.

4. De-attach the RFE element from its adaptor using a 5/32" Allan wrench.

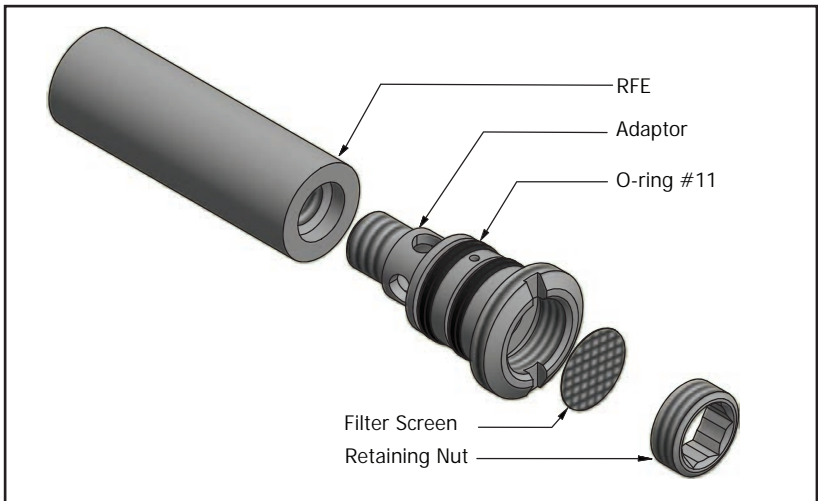

5. Clean or replace each of the removed parts as necessary. If alcohol is used for cleaning, allow time for drying.

Inspect the flow path inside the transducer for any visible signs of contaminant.

If necessary, flush the flow path through with alcohol. Thoroughly dry the flow paths by flowing clean dry gas through.

Be sure that no dust has collected on the O-ring seal, prior reassembling.

6. Re-assemble the RFE sub ass'y, and then carefully screw it into the inlet side.



Do not attempt installing the RFE sub ass'y into the unit's outlet side!!

7. Screw in the compression fittings.



NOTE: OVER TIGHTENING WILL DEFORM AND RENDER THE RFE DEFECTIVE.

It is advisable that at least one calibration point be checked after re-installing the inlet fitting-See section (g).



IT IS NOT RECOMMENDED TO ATTEMPT TO DISASSEMBLE, OR REPAIR MAXIMUM FLOW RATE SERIES MODELS 50 L/min, 100 L/min, 200 L/min, 500 L/min or 1000 L/min. DISASSEMBLY NECESSITATES RE-CALIBRATION.

7. CALIBRATION PROCEDURES



NOTE: REMOVAL OF THE FACTORY INSTALLED CALIBRATION SEALS AND/OR ANY ADJUSTMENTS MADE TO THE METER, AS DESCRIBED IN THIS SECTION, WILL VOID ANY CALIBRATION WARRANTY APPLICABLE.

7.1 Flow Calibration

OMEGA® Engineering Flow Calibration Laboratory offers professional calibration support for Mass Flow Meters, using precision calibrators under strictly controlled conditions. NIST traceable calibrations are available. Calibrations can also be performed at customers' site using available standards.

Factory calibrations are performed using NIST traceable precision volumetric calibrators incorporating liquid sealed frictionless actuators. Generally, calibrations are performed using dry nitrogen gas. The calibration can then be corrected to the appropriate gas desired based on relative correction [K] factors shown in the gas factor table - see Appendix 2. A reference gas, other than nitrogen, may be used to better approximate the flow characteristics of certain gases.

This practice is recommended when a reference gas is found with thermodynamic properties similar to the actual gas under consideration. The appropriate relative correction factor should be recalculated - see section 9. It is standard practice to calibrate Mass Flow Meters with dry nitrogen gas at 70° F (21.1 °C), 20 psig (1.4 bars) inlet pressure and 0 psig (0 bar) outlet pressure. It is best to calibrate the FMA1700A/1800A transducers to actual operating conditions. Specific gas calibrations of non-toxic and non-corrosive gases are available at specific conditions. Please contact your OMEGA® for a price quotation. It is recommended that a flow calibrator of at least four times better collective accuracy than that of the Mass Flow Meter to be calibrated be used. Equipment required for calibration includes a flow calibration standard and a certified high sensitivity multimeter (which together have a collective accuracy of ±0.25% or better), an insulated (plastic) screwdriver, a flow regulator (example: metering needle valve) installed upstream from the Mass Flow Meter and a pressure regulated source of dry filtered nitrogen gas (or other suitable reference gas).

The gas and ambient temperature, as well as inlet and outlet pressure conditions should be set up in accordance with actual operating conditions.

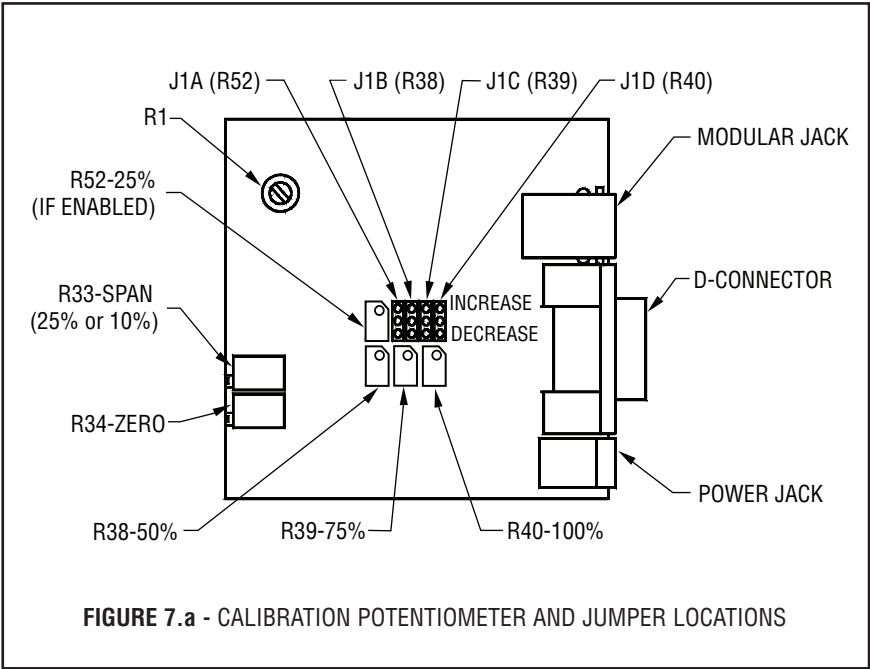

7.2 Calibration of FMA1700A/1800A Mass Flow Meters

All adjustments in this section are made from the outside of the meter, there is no need to disassemble any part of the instrument.

FMA1700A/1800A Mass Flow Meters may be field recalibrated/checked for the same range they were originally factory calibrated for. When linearity adjustment is needed, or flow range changes are being made proceed to step 7.3. Flow range changes may require a different Restrictor Flow Element (RFE). Consult OMEGA® for more information.

7.2.1 Connections and Initial Warm Up

At the 9-pin “D” connector of the FMA1700A/1800A transducer, connect the multimeter to output pins [2] and [3] for 0-5 VDC (or pins [8] and [9] for 4-20 mA)-(see Figure 2.a).

Power up the Mass Flow Meter for at least 30 minutes prior to commencing the calibration procedure.

7.2.2 ZERO Adjustment

Shut off the flow of gas into the Mass Flow Meter. To ensure that no seepage or leak occurs into the meter, it is good practice to temporarily disconnect the gas source. Using the multimeter and the insulated screwdriver, adjust the ZERO potentiometer

[R34] through the access window for 0 VDC (or 4 mA respectively) at zero flow.



CAUTION: The minimum voltage on 0-5 Vdc output can be in the range of 7 to 25 mV. Trying to reduce voltage below this level may increase negative zero shift. This shift may be invisible on devices without LCD display. Stop R34 zero potentiometer adjustment if voltage on 0-5 Vdc output is in the range from 7 to 25 mV and does not decrease any lower.

7.2.3 SPAN Adjustment

Reconnect the gas source. Using the flow regulator, adjust the flow rate to 100% of full scale flow. Check the flow rate indicated against the flow calibrator. If the deviation is less than $\pm 10\%$ of full scale reading, correct the SPAN potentiometer [R33] setting by using the insulated screwdriver through the access window, to eliminate any deviation. If the deviation is larger than $\pm 10\%$ of full scale reading, a defective condition may be present.

LIKELY REASONS FOR A MALFUNCTIONING SIGNAL MAY BE:

- ✓ Occluded or contaminated sensor tube.
- ✓ Leaking condition in the FMA1700A/1800A transducer or the gas line and fittings.
- ✓ For gases other than nitrogen, recheck appropriate “K” factor from the Gas Factor Table.
- ✓ Temperature and/or pressure correction errors.

See also section 8. TROUBLESHOOTING. If after attempting to remedy the above conditions, a malfunction still persists, return the meter for factory service, see section 1.1.

At this point the calibration is complete. However, it is advisable that several additional points between 0 and 100%, such as 25%, 50%, and 75% flow be checked. If discrepancies are found, proceed to step 7.3 for Linearity Adjustment.

7.3 Linearity Adjustment

7.3.1 Connections and Initial Warm Up

At the 9-pin "D" connector of the FMA1700A & FMA1800A transducer, connect the multimeter to output pins [2] and [3] for 0-5 VDC (or pins [8] and [9] for 4-20 mA)-(see Figure 2.a). If calibration to a new flow range or different gas is being performed, it may be necessary to remove any jumpers at J1.A, J1.B, J1.C, and J1.D before the beginning the linearizing procedure.

Power up the Mass Flow Meter for at least 30 minutes prior to commencing the calibration procedure.

7.3.2 ZERO Adjustment

Shut off the flow of gas into the Mass Flow Meter. To ensure that no seepage or leak occurs into the meter, it is good practice to temporarily disconnect the gas source. Using the multimeter and the insulated screwdriver, adjust the ZERO potentiometer [R34] through the access window for 0 VDC (or 4 mA respectively) at zero flow.



CAUTION: The minimum voltage on 0-5 Vdc output can be in the range of 7 to 25 mV. Trying to reduce voltage below this level may increase negative zero shift. This shift may be invisible on devices without LCD display. Stop R34 zero potentiometer adjustment if voltage on 0-5 Vdc output is in the range from 7 to 25 mV and does not decrease any lower.

7.3.3 25% Flow Adjustment (using R33 potentiometer)

Reconnect the gas source. Using the flow regulator, adjust the flow rate to 25% of full scale flow. Check the flow rate indicated against the flow calibrator.

Adjust the setting for potentiometer [R33] by using the insulated screwdriver through the access window, until the output of the flow meter reads 1.25VDC \pm 63mV (or 8mA \pm 0.25mA).

Using the flow regulator, adjust the flow rate until the output of the flow meter reads 0.5 VDC (or 5.6mA). Check the flow rate against the flow calibrator. If the flow rate indicated by the calibrator is within 10% \pm 1.5% of F.S. then skip paragraphs 7.3.4, 7.3.5 and proceed directly to paragraph 7.3.6, if not, perform 10% flow adjustment according to paragraph 7.3.4.

7.3.4 10% Flow Adjustment

Using the flow regulator, adjust the flow rate to 10% of full scale flow according to the calibrator. Check the flow rate indicated against the flow calibrator. Adjust the setting for potentiometer [R33] by using the insulated screwdriver through the access window, until the output of the flow meter reads 0.5VDC \pm 63mV (or 5.6mA \pm 0.25mA).

7.3.5 25% Flow Adjustment (using R52 potentiometer)

Using the flow regulator, adjust the flow rate to 25% of full scale flow according to the calibrator. Check the flow rate indicated against the flow calibrator. The output of the flow meter should read 1.25VDC \pm 63mV (or 8.0mA \pm 0.25mA). If the reading is outside of that range, place the jumper at [J1.A] as appropriate to increase or decrease the signal. Adjust the setting for potentiometer [R52] by using the insulated screwdriver through the access window, until reading is within specification.

7.3.6 50% Flow Adjustment

Using the flow regulator, increase the flow rate to 50% of full scale flow according to the calibrator. Check the flow rate indicated against the flow calibrator. The output of the flow meter should read 2.50VDC \pm 63mV (or 12mA \pm 0.25mA). If the reading is outside of that range, place the jumper at [J1.B] as appropriate to increase or decrease the signal. Adjust the setting for potentiometer [R38] by using the insulated screwdriver through the access window, until reading is within specification.

7.3.7 75% Flow Adjustment

Using the flow regulator, increase the flow rate to 75% of full scale flow according to calibrator. Check the flow rate indicated against the flow calibrator. The output of the flow meter should read 3.75VDC \pm 63mV (or 16mA \pm 0.25mA). If the reading is outside of that range, place the jumper at [J1.C] as appropriate to increase or decrease the signal. Adjust the setting for potentiometer [R39] by using the insulated screwdriver through the access window, until reading is within specification.

7.3.8 100% Flow Adjustment

Using the flow regulator, increase the flow rate to 100% of full scale flow. Check the flow rate indicated against the flow calibrator. The output of the flow meter should read 5.00VDC \pm 63mV (or 20mA \pm 0.25mA).

If the reading is outside of that range, place the jumper at [J3] as appropriate to increase or decrease the signal. Adjust the setting for potentiometer [R40] by using the insulated screwdriver through the access window, until reading is within specification.

Repeat steps 7.3.3 to 7.3.6 at least once more.

7.4 LCD Display Scaling

It may be desirable to re-scale the output reading on the LCD readout supplied with certain model FMA1700A/1800A transducers. Re-calibration for a new flow range

7.4.1 Access LCD Display Circuit

Carefully remove the LCD from the FMA1700A/1800A or panel mounted surface. Remove the aluminum housing on the side of the connection cable. Slide the LCD assembly out of the aluminum housing.

7.4.2 Adjust Scaling

Using a digital multimeter connected to either the 0 to 5 VDC or 4 to 20 mA signal at the 9-pin "D" connector, set the flow rate on the FMA1700A/1800A to full scale flow (5 VDC or 20mA). Maintain full scale flow, and adjust the potentiometer [R3] on the LCD printed circuit board to desired full scale flow reading.

7.4.3 Change Decimal Point

To change the decimal place on the LCD display readout, simply move the jumper to the appropriate location on the 8-pin header block. The numbers are printed to the side of the connections. Do not attempt to place more than one jumper for decimal setting.

JUMPER POSITION	MAXIMUM SCALABLE DISPLAY READING
"0"	1999
"3"	199.9
"2"	19.99
"1"	1.999

8. TROUBLESHOOTING

8.1 Common Conditions

Your Mass Flow Meter was thoroughly checked at numerous quality control points during and after manufacturing and assembly operations. It was calibrated according to your desired flow and pressure conditions for a given gas or a mixture of gases.

It was carefully packed to prevent damage during shipment. Should you feel that the instrument is not functioning properly please check for the following common conditions first:

Are all cables connected correctly? Are there any leaks in the installation? Is the power supply correctly selected according to requirements? When several meters are used a power supply with appropriate current rating should be selected.

Were the connector pinouts matched properly? When interchanging with other manufacturers' equipment, cables and connectors must be carefully wired for correct pin configurations. Is the pressure differential across the instrument sufficient?

8.2 Troubleshooting Guide

INDICATION	LIKELY REASON	REMEDY
lack of reading or output	power supply off	check connection of power supply
	fuse blown	disconnect FMA1700A/1800A transducer from power supply; remove the shorting condition or check polarities; fuse resets automatically
	filter screen obstructed at inlet	flush clean or disassemble to remove impediments or replace
	occluded sensor tube	flush clean or return to factory for replacement
	pc board defect	return to factory for replacement
	power supply problem	check power supply for appropriate output
unstable or no zero reading	gas leak	locate and correct
	pc board defective	return to factory for replacement
full scale output at “no flow” condition or with valve closed	defective sensor	return to factory for replacement
	gas leak	locate and correct
calibration off	gas metered is not the same as what meter was calibrated for	use matched calibration
	composition of gas changed	see K factor tables in APPENDIX 2
	gas leak	locate and correct
	pc board defective	return to factory for replacement
	RFE dirty	flush clean or disassemble to remove impediments
	occluded sensor tube	flush clean or return to factory for replacement
	filter screen obstructed at inlet	flush clean or disassemble to remove impediments or replace
	transducer is not mounted properly	check for any tilt or change in the mounting of the transducer; generally, units are calibrated for horizontal installation (relative to the sensor tube)

INDICATION	LIKELY REASON	REMEDY
No zero reading after 15 minute warm up time and no flow condition.	Embedded temperature has been changed.	Readjust ZERO potentiometer R34 through the access hole (see page 14 for details).
No zero reading after 15 minute warm up time and no flow condition. Display reading does not response on zero adjustment.	Power supply voltage is less than 11.0 Vdc.	Measure voltage on pins 4 and 5 of the 9 pin D-connector. If voltage is less than 11.0Vdc replace power supply with new one (regulated 12.0 Vdc, 250 mA minimum is recommended).
No zero reading after 15 minute warm up time and no flow condition. Display reading does not response on zero adjustment. But analog output 0-5 Vdc can be adjusted from 10mV up to 0.5 Vdc with zero potentiometer R34.	Wire is disconnected inside of the LCD Display.	Carefully remove the LCD from FMA1700A/1800A. Remove the aluminum housing on the side of the connection cable. Side the LCD assembly out of the aluminum housing. Check connection for all four wires. If any wire is disconnected restore connection and readjust zero potentiometer R34 to get zero reading on the display (ensure gas source is disconnected and no seepage or leak occurs in to the meter).
LCD Display remains blank when unit is powered up. But flow can be observed on analog output 0-5 Vdc (pis 2 and 3 of the D-connector).	LCD Display connector is not attached to the FMA1700A/1800A or connection is loose.	Check LCD connector (remove and reinstall LCD connector)
	Wire is disconnected inside of the LCD Display.	See instructions for pos. 3
LCD Display remains blank when unit is powered up. No response on the flow from analog output 0-5 Vdc (voltage is less than 15 mV).	Power supply is bad or polarity is reversed.	Measure voltage on pins 4 and 5 of the 9 pin D-connector. If voltage is less than 11.0Vdc replace power supply with new one (regulated 12.0 Vdc, 250 mA minimum is recommended). If polarity is reversed (reading is negative) make correct connection.
	PC board is defective.	Return FMA1700A/1800A to factory for repair.

INDICATION	LIKELY REASON	REMEDY
LCD Display reading does not correspond the correct flow range according analog output 0-5 Vdc signal.	LCD Display is adjusted for wrong flow range or engineering units.	Readjust LCD Display scaling for required full scale flow (see 7.4 on page 16).
LCD Display reading and analog output 0-5Vdc signal are fluctuate in wide range during the flow measurement.	Output 0-5 Vdc signal (pins 2 and 3 of the D-connector) is shorted on the GND or overloaded.	Check external connections to pins 2 and 3 of the D-connector. Make sure the load resistance is more than 1000 Ohm.
LCD Display reading does correspond the correct flow range, but 0-5 Vdc output signal does not change (always the same reading or around zero).	Output 0-5Vdc schematic is burned out or damaged.	Return FMA1700A/1800A to factory for repair.
LCD Display reading and 0-5 Vdc output voltage do correspond the correct flow range, but 4-20 mA output signal does not change (always the same or reading around 4.0 mA).	External loop resistance is open or more than 500 Ohm.	Check external connections to pins 8 and 9 of the D-connector. Make sure the loop resistance is less than 500 Ohm.
	Output 4-20 mA schematic is burned out or damaged.	Return FMA1700A/1800A to factory for repair.
Calibration is off (no more than 3.0 % F.S.).	FMA1700A/1800A has initial zero shift.	Shut off the flow of gas into the FMA1700A/1800A (ensure gas source is disconnected and no seepage or leak occurs in to the meter). Wait for 15 minute. with no flow condition and readjust zero potentiometer R34 to get zero reading on the display.

INDICATION	LIKELY REASON	REMEDY
<p>LCD Display reading is above maximum flow range and output voltage 0-5 Vdc signal is more than 5.5 Vdc when gas flows through the FMA1700A/1800A.</p>	<p>Sensor under swamping conditions (flow is more than 10% above maximum flow rate for particular FMA1700A/1800A).</p>	<p>Lower the flow through FMA1700A/1800A within calibrated range or shut down the flow completely. The swamping condition will end automatically.</p>
	<p>PC board is defective.</p>	<p>Return FMA1700A/1800A to factory for repair.</p>
<p>Gas flows through the FMA1700A/1800A, but LCD Display reading and output voltage 0-5 Vdc signal do not responds on the flow.</p>	<p>The gas flow is too low for particular model of FMA1700A/1800A.</p>	<p>Check maximum flow range on transducer's front panel and make required flow adjustment.</p>
	<p>FMA1700A/1800A Series Max Flow 10 L/min models: RFE is not connected properly to the inlet fitting.</p>	<p>Unscrew the inlet compression fitting of the meter and reinstall RFE (see 6.2.2 on page 12). NOTE: Calibration accuracy can be affected.</p>
	<p>Sensor or PC board is defective.</p>	<p>Return FMA1700A/1800A to factory for repair.</p>
<p>Gas does not flow through the FMA1700A/1800A with inlet pressure applied to the inlet fitting. LCD Display reading and output voltage 0-5 Vdc signal show zero flow.</p>	<p>Filter screen obstructed at inlet.</p>	<p>Flush clean or disassemble to remove impediments or replace the filter screen (see 6.2 on page 11). NOTE: Calibration accuracy can be affected.</p>
<p>Gas flows through the FMA1700A/1800A, but LCD Display reading is negative and output voltage 0-5 Vdc signal do not responds on the flow (reading near 10mV).</p>	<p>Direction of the gas flow is reversed.</p>	<p>Check the direction of gas flow as indicated by the arrow on the front of the meter and make required reconnection in the installation.</p>
	<p>FMA1700A/1800A is installed in the installation with back pressure conditions and gas leak exist in the system.</p>	<p>Locate and correct gas leak in the system. If FMA1700A/1800A has internal leak return it to factory for repair.</p>
<p>Gas flows through the FMA1700A/1800A, but LCD Display reading is negative and does not change according to gas flow. Output voltage 0-5 Vdc signal corresponds correct gas flow.</p>	<p>5.00 Vdc reference voltage (green wire) is disconnected inside of the LCD Display.</p>	<p>Carefully remove the LCD from FMA1700A/1800A. Remove the aluminum housing on the side of the connection cable. Side the LCD assembly out of the aluminum housing. Check connection for green wire (5.00 Vdc reference voltage). If any wire is disconnected restore connection.</p>

INDICATION	LIKELY REASON	REMEDY
FMA1700A/1800A is disconnected from the source of the gas (no flow conditions) but LCD Display reading is fluctuating in wide range. Output voltage 0-5 Vdc signal also fluctuating. The power supply voltage is 12.0 to 24.0 Vdc and stable.	Sensor or PC board is defective.	Return FMA1700A/1800A to factory for repair.
Reading on the LCD Display ten (hundreds) times less or more than actual gas flow. Output voltage 0-5 Vdc signal corresponds correct gas flow.	Decimal point jumper is installed in wrong position on the LCD Display Circuit.	Carefully remove the LCD from FMA1700A/1800A. Remove the aluminum housing on the side of the connection cable. Side the LCD assembly out of the aluminum housing. Reinstall jumper to the appropriate location on the 8-pin header block (see 7.4.3 on page 17).

For best results it is recommended that instruments are returned to the factory for servicing. See section 1.3 for return procedures.

8.3 Technical Assistance

OMEGA® Engineering will provide technical assistance over the phone to qualified repair personnel. Please call our Flow Department at 800-872-9436 Ext. 2298.

9. CALIBRATION CONVERSIONS FROM REFERENCE GASES

The calibration conversion incorporates the K factor. The K factor is derived from gas density and coefficient of specific heat. For diatomic gases:

$$K_{\text{gas}} = \frac{1}{d \times C_p}$$

where d = gas density (gram/liter)

C_p = coefficient of specific heat (cal/gram)

Note in the above relationship that d and C_p are usually chosen at the same conditions (standard, normal or other).

If the flow range of a Mass Flow Meter remains unchanged, a relative K factor is used to relate the calibration of the actual gas to the reference gas.

$$K = \frac{Q_a}{Q_r} = \frac{K_a}{K_r}$$

where Q_a = mass flow rate of an actual gas (sccm)

Q_r = mass flow rate of a reference gas (sccm)

K_a = K factor of an actual gas

K_r = K factor of a reference gas

For example, if we want to know the flow rate of oxygen and wish to calibrate with nitrogen at 1000 SCCM, the flow rate of oxygen is:

$$Q_{O_2} = Q_a = Q_r \times K = 1000 \times 0.9926 = 992.6 \text{ sccm}$$

where K = relative K factor to reference gas (oxygen to nitrogen)

APPENDIX 1

COMPONENTS DIAGRAM

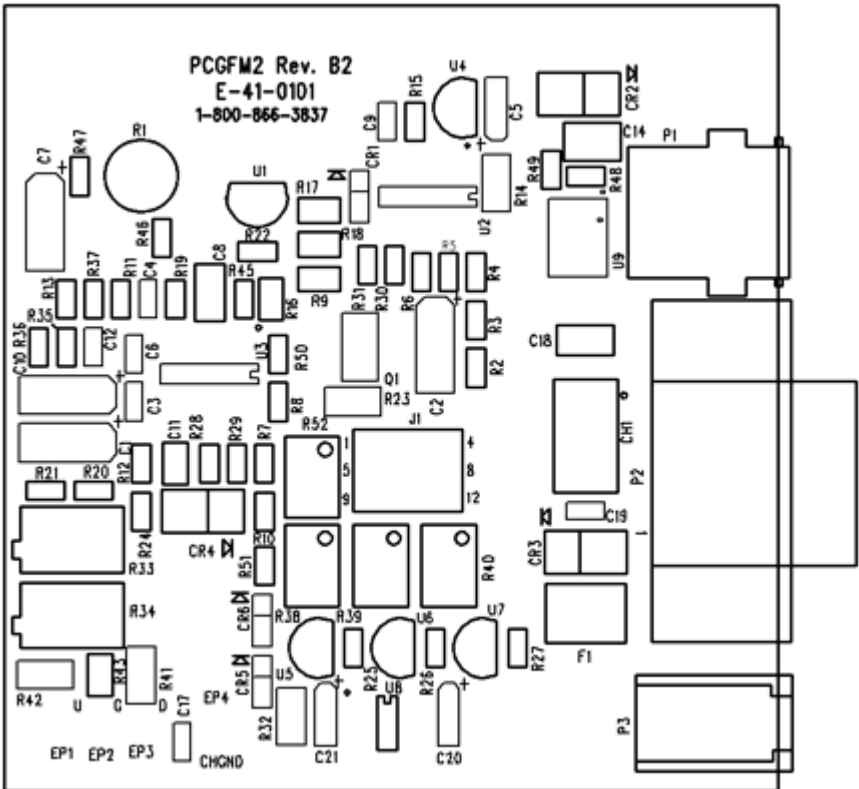

FMA1700A/1800A METERING PC BOARD

APPENDIX 2
GAS FACTOR TABLE (“K” FACTORS)

⚠ CAUTION: K-Factors at best are only an approximation. K factors should not be used in applications that require accuracy better than +/- 5 to 10%.

ACTUAL GAS	K FACTOR Relative to N ₂	Cp [Cal/g]	Density [g/l]
Acetylene C ₂ H ₂	.5829	.4036	1.162
Air	1.0000	.240	1.293
Allene (Propadiene) C ₃ H ₄	.4346	.352	1.787
Ammonia NH ₃	.7310	.492	.760
*Argon Ar	1.4573	.1244	1.782
*Argon AR-1 (>10 L/min)	1.205	.1244	1.782
Arsine AsH ₃	.6735	.1167	3.478
Boron Trichloride BCl ₃	.4089	.1279	5.227
Boron Trifluoride BF ₃	.5082	.1778	3.025
Bromine Br ₂	.8083	.0539	7.130
Boron Tribromide Br ₃	.38	.0647	11.18
Bromine PentaTrifluoride BrF ₅	.26	.1369	7.803
Bromine Trifluoride BrF ₃	.3855	.1161	6.108
Bromotrifluoromethane (Freon-13 B1) CBrF ₃	.3697	.1113	6.644
1,3-Butadiene C ₄ H ₆	.3224	.3514	2.413
Butane C ₄ H ₁₀	.2631	.4007	2.593
1-Butene C ₄ H ₈	.2994	.3648	2.503
2-Butene C ₄ H ₈ CIS	.324	.336	2.503
2-Butene C ₄ H ₈ TRANS	.291	.374	2.503
*Carbon Dioxide CO ₂	.7382	.2016	1.964
*Carbon Dioxide CO ₂ -1 (>10 L/min)	.658	.2016	1.964
Carbon Disulfide CS ₂	.6026	.1428	3.397
Carbon Monoxide CO	1.00	.2488	1.250
Carbon Tetrachloride CCl ₄	.31	.1655	6.860
Carbon Tetrafluoride (Freon-14)CF ₄	.42	.1654	3.926
Carbonyl Fluoride COF ₂	.5428	.1710	2.945
Carbonyl Sulfide COS	.6606	.1651	2.680
Chlorine Cl ₂	.86	.114	3.163
Chlorine Trifluoride ClF ₃	.4016	.1650	4.125
Chlorodifluoromethane (Freon-22)CHClF ₂	.4589	.1544	3.858
Chloroform CHCl ₃	.3912	.1309	5.326
Chloropentafluoroethane(Freon-115)C ₂ ClF ₅	.2418	.164	6.892
Chlorotrifluoromethane (Freon-13) CClF ₃	.3834	.153	4.660
CyanogenC ₂ N ₂	.61	.2613	2.322
CyanogenChloride ClCN	.6130	.1739	2.742
Cyclopropane C ₃ H ₅	.4584	.3177	1.877

* Flow rates indicated () is the maximum flow range of the Mass Flow meter being used.

ACTUAL GAS	K FACTOR Relative to N ₂	Cp [Cal/g]	Density [g/l]
Deuterium D ₂	1.00	1.722	1.799
Diborane B ₂ H ₆	.4357	.508	1.235
Dibromodifluoromethane CBr ₂ F ₂	.1947	.15	9.362
Dichlorodifluoromethane (Freon-12) CCl ₂ F ₂	.3538	.1432	5.395
Dichlorofluoromethane (Freon-21) CHCl ₂ F	.4252	.140	4.592
Dichloromethylsilane (CH ₃) ₂ SiCl ₂	.2522	.1882	5.758
Dichlorosilane SiH ₂ Cl ₂	.4044	.150	4.506
Dichlorotetrafluoroethane (Freon-114) C ₂ Cl ₂ F ₄	.2235	.1604	7.626
1,1-Difluoroethylene (Freon-1132A) C ₂ H ₂ F ₂	.4271	.224	2.857
Dimethylamine (CH ₃) ₂ NH	.3714	.366	2.011
Dimethyl Ether (CH ₃) ₂ O	.3896	.3414	2.055
2,2-Dimethylpropane C ₃ H ₁₂	.2170	.3914	3.219
Ethane C ₂ H ₆	.50	.420	1.342
Ethanol C ₂ H ₆ O	.3918	.3395	2.055
Ethyl Acetylene C ₄ H ₆	.3225	.3513	2.413
Ethyl Chloride C ₂ H ₅ Cl	.3891	.244	2.879
Ethylene C ₂ H ₄	.60	.365	1.251
Ethylene Oxide C ₂ H ₄ O	.5191	.268	1.965
Fluorine F ₂	.9784	.1873	1.695
Fluoroform (Freon-23) CHF ₃	.4967	.176	3.127
Freon-11 CCl ₃ F	.3287	.1357	6.129
Freon-12 CCl ₂ F ₂	.3538	.1432	5.395
Freon-13 CClF ₃	.3834	.153	4.660
Freon-13B1 CBrF ₃	.3697	.1113	6.644
Freon-14 CF ₄	.4210	.1654	3.926
Freon-21 CHCl ₂ F	.4252	.140	4.592
Freon-22 CHClF ₂	.4589	.1544	3.858
Freon-113 CCl ₂ FCClF ₂	.2031	.161	8.360
Freon-114 C ₂ Cl ₂ F ₄	.2240	.160	7.626
Freon-115 C ₂ ClF ₅	.2418	.164	6.892
Freon-C318 C ₄ F ₈	.1760	.185	8.397
Germane GeH ₄	.5696	.1404	3.418
Germanium Tetrachloride GeCl ₄	.2668	.1071	9.565
*Helium He	1.454	1.241	.1786
*Helium He-1 (>50 L/min)	2.43	1.241	.1786
*Helium He-2 (>10-50 L/min)	2.05	1.241	.1786
Hexafluoroethane C ₂ F ₆ (Freon-116)	.2421	.1834	6.157
Hexane C ₆ H ₁₄	.1792	.3968	3.845
*Hydrogen H ₂ -1	1.0106	3.419	.0899
*Hydrogen H ₂ -2 (>10-100 L)	1.35	3.419	.0899
*Hydrogen H ₂ -3 (>100 L)	1.9	3.419	.0899

* Flow rates indicated () is the maximum flow range of the Mass Flow meter being used.

ACTUAL GAS	K FACTOR Relative to N ₂	Cp [Cal/g]	Density [g/l]
Hydrogen Bromide HBr	1.000	.0861	3.610
Hydrogen Chloride HCl	1.000	.1912	1.627
Hydrogen Cyanide HCN	.764	.3171	1.206
Hydrogen Fluoride HF	.9998	.3479	.893
Hydrogen Iodide HI	.9987	.0545	5.707
Hydrogen Selenide H ₂ Se	.7893	.1025	3.613
Hydrogen Sulfide H ₂ S	.80	.2397	1.520
Iodine Pentafluoride IF ₅	.2492	.1108	9.90
Isobutane CH(CH ₃) ₃	.27	.3872	3.593
Isobutylene C ₄ H ₈	.2951	.3701	2.503
Krypton Kr	1.453	.0593	3.739
*Methane CH ₄	.7175	.5328	.7175
*Methane CH ₄ -1 (>10 L/min)	.75	.5328	.7175
Methanol CH ₃	.5843	.3274	1.429
Methyl Acetylene C ₃ H ₄	.4313	.3547	1.787
Methyl Bromide CH ₃ Br	.5835	.1106	4.236
Methyl Chloride CH ₃ Cl	.6299	.1926	2.253
Methyl Fluoride CH ₃ F	.68	.3221	1.518
Methyl Mercaptan CH ₃ SH	.5180	.2459	2.146
Methyl Trichlorosilane (CH ₃)SiCl ₃	.2499	.164	6.669
Molybdenum Hexafluoride MoF ₆	.2126	.1373	9.366
Monoethylamine C ₂ H ₅ NH ₂	.3512	.387	2.011
Monomethylamine CH ₃ NH ₂	.51	.4343	1.386
Neon NE	1.46	.246	.900
Nitric Oxide NO	.990	.2328	1.339
Nitrogen N ₂	1.000	.2485	1.25
Nitrogen Dioxide NO ₂	.737	.1933	2.052
Nitrogen Trifluoride NF ₃	.4802	.1797	3.168
Nitrosyl Chloride NOCl	.6134	.1632	2.920
Nitrous Oxide N ₂ O	.7128	.2088	1.964
Octafluorocyclobutane (Freon-C318) C ₄ F ₈	.176	.185	8.397
Oxygen O ₂	.9926	.2193	1.427
Oxygen Difluoride OF ₂	.6337	.1917	2.406
Ozone	.446	.195	2.144
Pentaborane B ₅ H ₉	.2554	.38	2.816
Pentane C ₅ H ₁₂	.2134	.398	3.219
Perchloryl Fluoride ClO ₃ F	.3950	.1514	4.571
Perfluoropropane C ₃ F ₈	.174	.197	8.388
Phosgene COCl ₂	.4438	.1394	4.418
Phosphine PH ₃	.759	.2374	1.517

* Flow rates indicated () is the maximum flow range of the Mass Flow meter being used.

ACTUAL GAS	K FACTOR Relative to N ₂	Cp [Cal/g]	Density [g/l]
Phosphorous Oxychloride POCl ₃	.36	.1324	6.843
Phosphorous Pentafluoride PH ₅	.3021	.1610	5.620
Phosphorous Trichloride PCl ₃	.30	.1250	6.127
Propane C ₃ H ₈	.35	.399	1.967
Propylene C ₃ H ₆	.40	.366	1.877
Silane SiH ₄	.5982	.3189	1.433
Silicon Tetrachloride SiCl ₄	.284	.1270	7.580
Silicon Tetrafluoride SiF ₄	.3482	.1691	4.643
Sulfur Dioxide SO ₂	.69	.1488	2.858
Sulfur Hexafluoride SF ₆	.2635	.1592	6.516
Sulfuryl Fluoride SO ₂ F ₂	.3883	.1543	4.562
Tetrafluoroethane (Forane 134A) CF ₃ CH ₂ F	.5096	.127	4.224
Tetrafluorohydrazine N ₂ F ₄	.3237	.182	4.64
Trichlorofluoromethane (Freon-11) CCl ₃ F	.3287	.1357	6.129
Trichlorosilane SiHCl ₃	.3278	.1380	6.043
1,1,2-Trichloro-1,2,2 Trifluoroethane (Freon-113) CCl ₂ FCF ₂	.2031	.161	8.36
Triisobutyl Aluminum (C ₄ H ₉) ₃ Al	.0608	.508	8.848
Titanium Tetrachloride TiCl ₄	.2691	.120	8.465
Trichloro Ethylene C ₂ HCl ₃	.32	.163	5.95
Trimethylamine (CH ₃) ₃ N	.2792	.3710	2.639
Tungsten Hexafluoride WF ₆	.2541	.0810	13.28
Vinyl Bromide CH ₂ CHBr	.4616	.1241	4.772
Vinyl Chloride CH ₂ CHCl	.48	.12054	2.788
Xenon Xe	1.44	.0378	5.858

APPENDIX 3

DIMENSIONAL DRAWINGS

10, 50, 100 L/min MAXIMUM FLOW SERIES MASS FLOW METERS

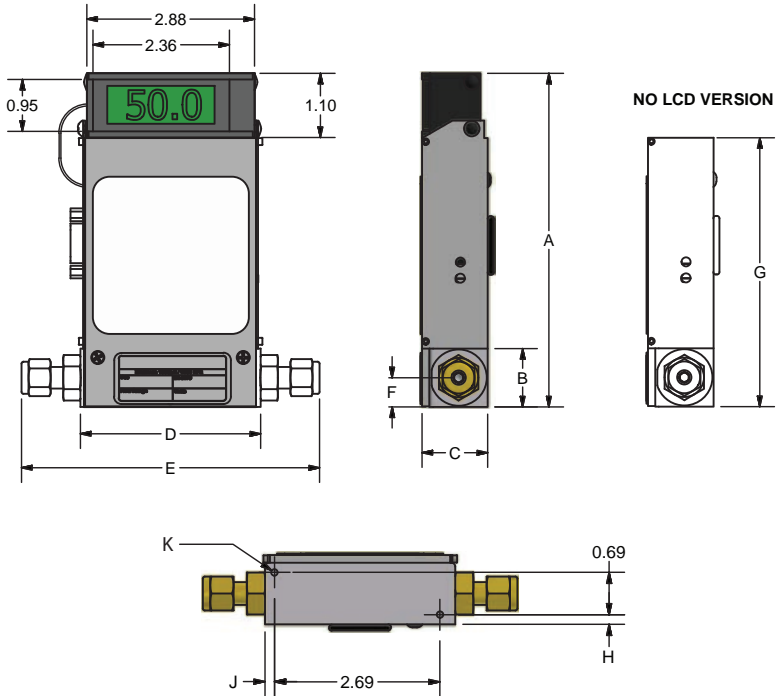

MODEL	CONNECTION COMPRESSION FITTING	DIMENSION INCH (MM)									
		LCD VERSION						NO LCD	MOUNTING HOLE		
		A	B	C	D	E	F		G	H	J
10 L/min	1/4"-Tube O Diameter	5.72 (145.3)	1.00 (25.4)	1.13 (28.6)	3.09 (78.6)	5.10 (129.6)	0.5 (12.7)	4.61 (117.1)	0.16 (4.0)	0.16 (4.0)	6-32 x 0.13
50 L/min	1/4"-Tube O Diameter	6.10 (154.9)	1.38 (34.9)	1.25 (31.8)	4.13 (104.8)	6.13 (155.8)	0.63 (15.9)	4.99 (126.7)	0.28 (7.1)	1.08 (27.3)	6-32 x 0.10
100 L/min	3/8"-Tube O Diameter	6.10 (154.9)	1.38 (34.9)	1.25 (31.8)	4.13 (104.8)	6.25 (158.7)	0.63 (15.9)	4.99 (126.7)	0.28 (7.1)	1.08 (27.3)	6-32 x 0.10

200, 500, 1000 L/min MAXIMUM FLOW SERIES MASS FLOW METERS

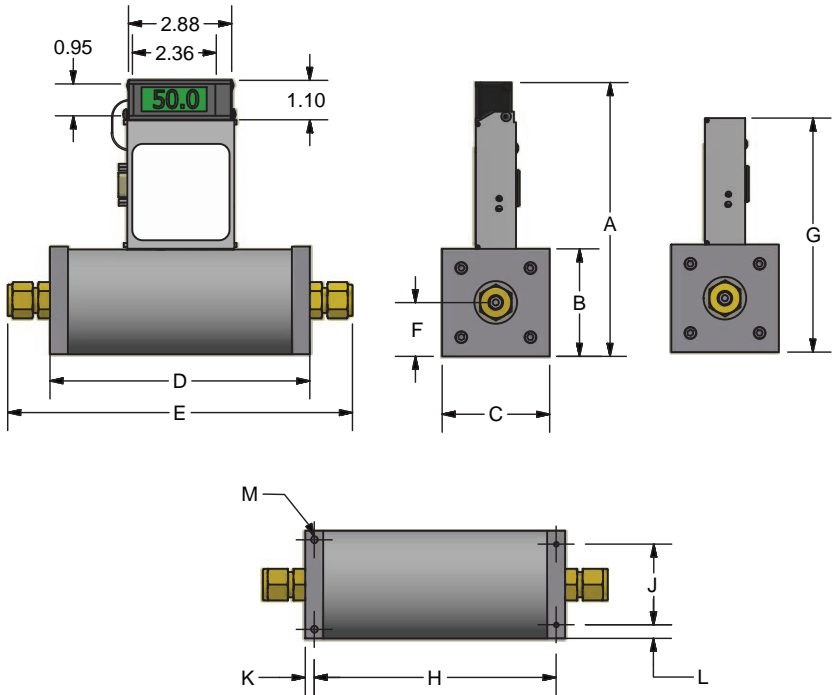

MAXIMUM FLOW SERIES	CONNECTION COMPRESSION FITTING (Except Model FMA1700A/1800A Series Max Flow 1000 L/min)	DIMENSION INCH (MM)											
		LCD VERSION						NO LCD	MOUNTING HOLE				
		A	B	C	D	E	F	G	H	J	K	L	M
200 L/min	3/4"-Tube O Diameter	6.73 (170.8)	2.00 (80.8)	1.75 (44.5)	6.69 (169.8)	8.81 (223.7)	0.88 (22.2)	5.62 (142.6)	4.69 (119.0)	1.39 (35.3)	1.00 (25.4)	0.18 (4.6)	10-24 x 0.25
500 L/min	1/2"-Tube O Diameter	7.64 (194.0)	3.00 (76.2)	3.00 (76.2)	7.25 (184.2)	9.65 (245.1)	1.5 (38.1)	6.53 (165.8)	6.75 (171.5)	2.25 (57.2)	0.25 (6.4)	0.38 (9.5)	1/4-20 x 0.35
1000 L/min	3/4"- NPT Female	8.66 (220.0)	4.00 (101.6)	4.00 (101.6)	7.30 (185.4)	-	2.00 (50.8)	7.55 (191.8)	6.80 (172.7)	3.00 (76.2)	0.25 (6.4)	0.50 (12.7)	1/4-20 x 0.35

PARTS OF THE FLOW METER

LEFT AND RIGHT VIEWS

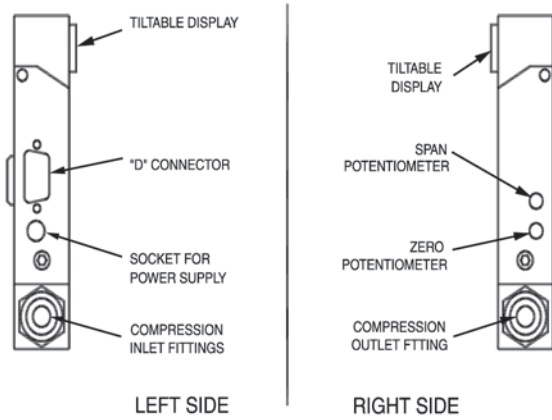

FRONT VIEW

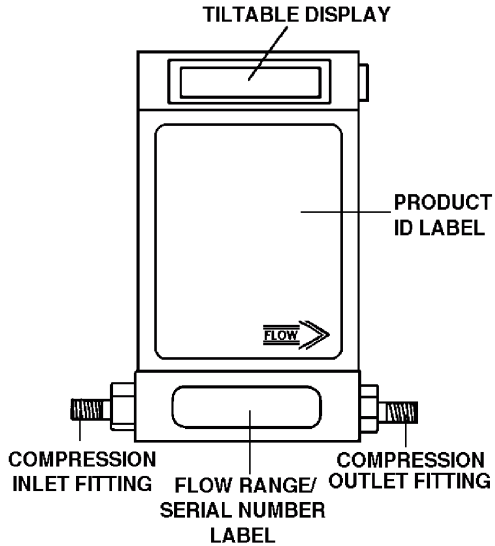

WARRANTY/DISCLAIMER

OMEGA ENGINEERING, INC. warrants this unit to be free of defects in materials and workmanship for a period of **13 months** from date of purchase. OMEGA's WARRANTY adds an additional one (1) month grace period to the normal **one (1) year product warranty** to cover handling and shipping time. This ensures that OMEGA's customers receive maximum coverage on each product.

If the unit malfunctions, it must be returned to the factory for evaluation. OMEGA's Customer Service Department will issue an Authorized Return (AR) number immediately upon phone or written request. Upon examination by OMEGA, if the unit is found to be defective, it will be repaired or replaced at no charge. OMEGA's WARRANTY does not apply to defects resulting from any action of the purchaser, including but not limited to mishandling, improper interfacing, operation outside of design limits, improper repair, or unauthorized modification. This WARRANTY is VOID if the unit shows evidence of having been tampered with or shows evidence of having been damaged as a result of excessive corrosion; or current, heat, moisture or vibration; improper specification; misapplication; misuse or other operating conditions outside of OMEGA's control. Components in which wear is not warranted, include but are not limited to contact points, fuses, and triacs.

OMEGA is pleased to offer suggestions on the use of its various products. However, OMEGA neither assumes responsibility for any omissions or errors nor assumes liability for any damages that result from the use of its products in accordance with information provided by OMEGA, either verbal or written. OMEGA warrants only that the parts manufactured by the company will be as specified and free of defects. OMEGA MAKES NO OTHER WARRANTIES OR REPRESENTATIONS OF ANY KIND WHATSOEVER, EXPRESSED OR IMPLIED, EXCEPT THAT OF TITLE, AND ALL IMPLIED WARRANTIES INCLUDING ANY WARRANTY OF MERCHANTABILITY AND FITNESS FOR A PARTICULAR PURPOSE ARE HEREBY DISCLAIMED. LIMITATION OF LIABILITY: The remedies of purchaser set forth herein are exclusive, and the total liability of OMEGA with respect to this order, whether based on contract, warranty, negligence, indemnification, strict liability or otherwise, shall not exceed the purchase price of the component upon which liability is based. In no event shall OMEGA be liable for consequential, incidental or special damages.

CONDITIONS: Equipment sold by OMEGA is not intended to be used, nor shall it be used: (1) as a "Basic Component" under 10 CFR 21 (NRC), used in or with any nuclear installation or activity; or (2) in medical applications or used on humans. Should any Product(s) be used in or with any nuclear installation or activity, medical application, used on humans, or misused in any way, OMEGA assumes no responsibility as set forth in our basic WARRANTY/DISCLAIMER language, and, additionally, purchaser will indemnify OMEGA and hold OMEGA harmless from any liability or damage whatsoever arising out of the use of the Product(s) in such a manner.

RETURN REQUESTS/INQUIRIES

Direct all warranty and repair requests/inquiries to the OMEGA Customer Service Department. BEFORE RETURNING ANY PRODUCT(S) TO OMEGA, PURCHASER MUST OBTAIN AN AUTHORIZED RETURN (AR) NUMBER FROM OMEGA'S CUSTOMER SERVICE DEPARTMENT (IN ORDER TO AVOID PROCESSING DELAYS). The assigned AR number should then be marked on the outside of the return package and on any correspondence.

The purchaser is responsible for shipping charges, freight, insurance and proper packaging to prevent breakage in transit.

FOR **WARRANTY** RETURNS, please have the following information available BEFORE contacting OMEGA:

1. Purchase Order number under which the product was PURCHASED,
2. Model and serial number of the product under warranty, and
3. Repair instructions and/or specific problems relative to the product.

FOR **NON-WARRANTY** REPAIRS, consult OMEGA for current repair charges. Have the following information available BEFORE contacting OMEGA:

1. Purchase Order number to cover the COST of the repair,
2. Model and serial number of the product, and
3. Repair instructions and/or specific problems relative to the product.

OMEGA's policy is to make running changes, not model changes, whenever an improvement is possible. This affords our customers the latest in technology and engineering.

OMEGA is a registered trademark of OMEGA ENGINEERING, INC.

© Copyright 2009 OMEGA ENGINEERING, INC. All rights reserved. This document may not be copied, photocopied, reproduced, translated, or reduced to any electronic medium or machine-readable form, in whole or in part, without the prior written consent of OMEGA ENGINEERING, INC.

Where Do I Find Everything I Need for Process Measurement and Control? **OMEGA... Of Course!** *Shop online at omega.comSM*

TEMPERATURE

- Thermocouple, RTD & Thermistor Probes, Connectors, Panels & Assemblies
- Wire: Thermocouple, RTD & Thermistor
- Calibrators & Ice Point References
- Recorders, Controllers & Process Monitors
- Infrared Pyrometers

PRESSURE, STRAIN AND FORCE

- Transducers & Strain Gages
- Load Cells & Pressure Gages
- Displacement Transducers
- Instrumentation & Accessories

FLOW/LEVEL

- Rotameters, Gas Mass Flowmeters & Flow Computers
- Air Velocity Indicators
- Turbine/Paddlewheel Systems
- Totalizers & Batch Controllers

pH/CONDUCTIVITY

- pH Electrodes, Testers & Accessories
- Benchtop/Laboratory Meters
- Controllers, Calibrators, Simulators & Pumps
- Industrial pH & Conductivity Equipment

DATA ACQUISITION

- Data Acquisition & Engineering Software
- Communications-Based Acquisition Systems
- Plug-in Cards for Apple, IBM & Compatibles
- Datalogging Systems
- Recorders, Printers & Plotters

HEATERS

- Heating Cable
- Cartridge & Strip Heaters
- Immersion & Band Heaters
- Flexible Heaters
- Laboratory Heaters

ENVIRONMENTAL MONITORING AND CONTROL

- Metering & Control Instrumentation
- Refractometers
- Pumps & Tubing
- Air, Soil & Water Monitors
- Industrial Water & Wastewater Treatment
- pH, Conductivity & Dissolved Oxygen Instruments