

# UFM-DQG Series

## Clamp on Ultrasonic Flow Meter/Data Logger For 2.5 in to 48 in Pipes

### DESCRIPTION

The UFM-DQG transit time ultrasonic flow meter measures volumetric flow and heating/cooling energy rates in clean liquids as well as those with small amounts of suspended solids or aeration, such as surface water or raw sewage.

UFM-DQG flow and energy meters clamp onto the outside of pipes and do not contact the internal liquid.

### BENEFITS

By clamping onto the outside of pipes, the meters have inherent advantages over other flow meter technologies, including:

- Reduced installation time and cost
- Non-invasive, non-contact measurement
- Continued operation during installation—no need to shut down the process
- No pressure head loss
- No moving parts to maintain or replace

### FEATURES

- Large, bi-directional flow measuring range
- Data log up to 8 records
- Modbus® RTU or BACnet® MS/TP over EIA-485; BACnet/IP, EtherNet/IP, or Modbus TCP/IP; AquaCUE®/BEACON® connectivity
- Configure and troubleshoot over USB with SoloCUE
- Reynolds, ultrasonic speed and temperature compensation
- Large, easy-to-read graphical display
- Rugged, aluminum enclosure for a long service life in harsh environments

### APPLICATIONS

The UFM-DQG meter is available in a variety of configurations that permit the user to select a meter with features suitable to meet particular application requirements.

The UFM-DQG meter is available in two versions:

- A flow meter for water delivery, sewage, cooling water, water-glycol mixtures, alcohols and chemicals
- A heating/cooling energy flow meter used in conjunction with dual clamp-on RTDs for temperature measurement—ideal for hydronic process and HVAC applications

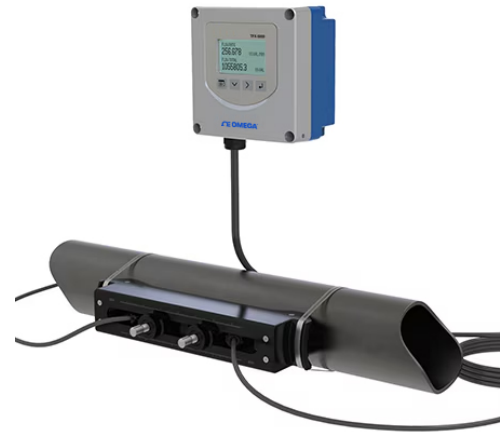

### OPERATION

Transit time flow meters measure the time difference between the travel time of an ultrasound wave going *with* the fluid flow and *against* the fluid flow. The time difference is used to calculate the velocity of the fluid traveling in a closed-pipe system. The transducers used in transit time measurements operate alternately as transmitters and receivers. Transit time measurements are bi-directional and are most effective for fluids that have low concentrations of suspended solids and are sonically conductive.

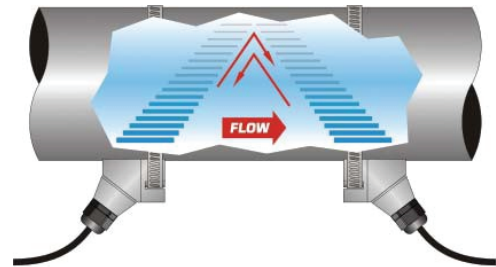

An ultrasonic meter equipped with heat flow capabilities measures the rate and quantity of heat delivered or removed from devices such as heat exchangers. By measuring the volumetric flow rate of the heat exchanger liquid, the temperature at the inlet pipe and the temperature at the outlet pipe, the energy usage can be calculated.

## SPECIFICATIONS

### System

<b>Liquid Types</b>	Most clean liquids or liquids containing small amounts of suspended solids or gas bubbles	
<b>Flow Accuracy</b>	Medium and Large Pipes (RZ, NZ, WZ, HZ, LZ, YZ, JZ, KZ)	$\pm 0.5\% \pm 0.0049$ ft/s (0.015 m/s)
	Small Pipes (CA-CT, UZ)	1 in. (25 mm) and larger = $\pm 1\% \pm 0.03$ ft/s (0.009 m/s) 3/4 in. (19 mm) and smaller = $\pm 1\%$ of full scale
<b>Repeatability</b>	0.2% above 1.5 ft/s	
<b>Velocity</b>	Medium and Large Pipes	Up to 40 ft/s, depending on pipe and fluid
	Small Pipes	Up to 20 ft/s, depending on pipe and fluid
<b>Certification and Compliance</b>	<b>General Safety (all models):</b> cCSAus, CE, Pollution Degree 2, CE compliance to Low Voltage Directive, 2014/35/EU <b>Hazardous Location transmitter and transducers:</b> CSA-c-us Class I Division 2 Groups ABCD T4 Requires flexible conduit Not available with UZ, HZ or JZ and KZ (Easy Rail) transducers, Auxiliary Dry Contact card or units with AquaCUE/BEACON endpoints	

### Transmitter

<b>Power Options</b>	24V DC/AC	9...28V DC @ 8 W max. or 20...26 AC 47...63 Hz @ 0.5 A max., 2 Amp slow-blow fuse, not field replaceable
	Mains AC	85...264V AC 47...63 Hz @ 24VA max. 1 Amp slow-blow fuse, manually field replaceable Over-Voltage Rating Category II (CAT II)
<b>Display</b>	Options	Display with keypad or no display/keypad
	Keypad	4-button navigation, keypad with tactile feedback; polyester film
	Display	128 × 64 pixel LED backlit graphical display; adjustable brightness and timeout; polycarbonate window
	Flow rate/total	8-digit
<b>Enclosure</b>	NEMA Type 4, IP67	
<b>Construction</b>	Aluminum construction; painted; wall, panel or pipe mounting; stainless steel fasteners and mounting hardware; EPDM gasket	
	Conduit Holes	(4) 1/2 in. NPT, M20 × 1.5 or 1/2 BSPP; cable glands available for NPT and M20
<b>Environmental Ratings</b>	Pollution Degree	2
	Altitude Restriction	Up to 2000 m (6561 ft)
	Ambient Temperature Range	-4...140° F (-20...60° C)
	Storage Temperature Range	-40...176° F (-40...80° C)
	Humidity	0...85%, non-condensing
<b>Configuration</b>	Via optional keypad or SoloCUE configuration software; SoloCUE available on DVD	
<b>Units (Field-Selectable)</b>	Velocity	feet/second, meters/second
	Volumetric total	US Gallons, Million Gallons, Imperial Gallons, Million Imperial Gallons, Acre-Feet, Liters, Hectoliters, Cubic Meters, Cubic Feet, Oil Barrels (42 gallons), Fluid Barrels (31.5 gallons), Imperial Fluid Barrels (36 imperial gallons), Pounds (Kilograms) and custom units
	Flow rate	Acre Feet/Day, Liters/Second, Liters/Minute, Liters/Hour, Cubic Meters/Second, Cubic Meters/Minute, Cubic Meters/Hour, Cubic Feet/Minute, Cubic Feet/Minute, Cubic Feet/Hour, Gallons/Second, Gallons/Minute, Gallons/Hour, Million Gallons/Day, Imperial Gallons/Second, Imperial Gallons/Minute, Imperial Gallons/Hour, Million Imperial Gallons/Day, Oil Barrels/Day, Fluid Barrels/Day, Imperial Fluid Barrels/Day and custom units
	Energy total (energy meters)	British Thermal Unit (Btu), Thousand Btu, Millions Btu, Kilocalories, Mega calories, Kilowatt-hour, Megawatt hour, Kilojoules, Mega joules, Ton-hour (Refrigeration)
	Heat/cooling rate (energy meters)	Btu/hour, Thousand Btu/hour, Millions Btu/hour, Ton (Refrigeration), Watts, Kilowatts, Megawatts, Kilojoules/hour, Mega joules/hour, Kilocalories/hour, Mega calories/hour

		Flow Meter	Energy Meter
<b>Inputs and Outputs</b>	0/4...20 mA output	One 16-bit, isolated, max 800 Ohms, internal or external power	Two 16-bit, isolated, max 800 Ohms, internal or external power
	Digital input	One 5...30V DC, isolated, externally or internally sourced, reset totalizer or alarm output	
	Digital output	Two selectable pulse, alarm, fl w direction, sink isolated open collector, 5...30V DC, max. 50 mA externally or internally sourced	Three selectable pulse, frequency, alarm, fl w direction, isolated open collector, 5...30V DC, externally or internally sourced
		Frequency output: 50% duty cycle, 63...10k Hz maximum frequency	
		Pulse (totalizer) output: 5 kHz max. output, open collector, pulse width 5...500 ms programmable	
RTD (energy only)	None	Two 2-wire, 3-wire or 4-wire Pt100/Pt1000 RTD inputs; Range of -40...200° C; Clamp-on resistor kits available	
<b>Ports</b>	Programming	USB 2.0 mini B connector for connection to a device with SoloCUE configuration software	
	EIA-485	Modbus RTU command set or BACnet MS/TP; Baud rates 9600, 14400, 19200, 38400, 57600, 76800, 115k; terminating resistor selectable	
	Ethernet	Optional 10/100 Base T RJ45, communication via Modbus TCP/IP, EtherNet/IP, or BACnet/IP with webserver	
	AquaCUE/BEACON	Connectivity to AquaCUE/BEACON endpoint (LTE cellular)	
<b>Data Logging</b>	Number of points	Up to 8 parameters per record. Selectable 1 second to 1 day Transfer logs via memory card	
	Real Time Clock	Backed up with a super capacitor, minimum of 32 days of data retention without power; Requires no servicing	
	MicroSD card slot	8 GB card, included with transmitter	
<b>Alarms</b>	Records 150 previous alarms, warnings or errors		
<b>Languages</b>	English		
<b>Security</b>	Four levels: Read-only, Operator, Service and Admin; 6-digit passcode number; selectable auto logout		

## Transducers

Model	Construction	Cable Length Max.	Pipe/Tubing Sizes	Flow Rate Max. GPM (LPM)	Pipe/Tubing Materials	Protection
CA-CT fixed small pipe	CPVC, Ultem®, Nylon cord grip Polyethylene cable jacket; -40...194° F (-40...90° C)	100 ft (30 m)	0.5...2 in. (12...50 mm)	190 (720)	See <sup>2</sup>	NEMA 6/IP67
UZ 1 adjustable small pipe	CPVC, Ultem, and anodized aluminum track system; Nickel-plated brass connector with Teflon insulation; -40...194° F (-40...90° C)	100 ft (30 m)	0.5...2 in. (12...50 mm)	190 (720)		NEMA 12
NZ 1 standard pipe	PVC, Ultem®, Nylon cord grip Polyethylene cable jacket; -40...194° F (-40...90° C)	300 ft (90 m)	2.5...12 in. (DN65...DN300)	4000 (15,000)		NEMA 6/IP67
RZ 1 standard pipe	PBT glass filled, Ultem®, Nylon cord grip; PVC cable jacket; -40...250° F (-40...121° C)	300 ft (90 m)	2.5...12 in. (DN65...DN300)	4000 (15,000)		NEMA 6/IP67
JZ, KZ 1 standard pipe, integrated rail	PBT glass filled, Ultem, Nylon cord grip; PVC cable jacket; -40...250° F (-40...121° C)	300 ft (90 m)	2.5...6 in. (DN65...DN150) 2.5...12 in. (DN65...DN300)	4000 (15,000)		NEMA 6/IP67
WZ 1 standard pipe, submersible	CPVC, Ultem, Nylon cord grip Polyethylene cable jacket; -40...194° F (-40...90° C)	300 ft (90 m)	2.5...12 in. (DN65...DN300)	4000 (15,000)		NEMA 6P/IP68
HZ 1 high temperature	PTFE, Vespel, Nickel-plated brass cord grip; PFA cable jacket; -40...350° F (-40...176° C)	300 ft (90 m)	2.5...12 in. (DN65...DN300)	4000 (15,000)		NEMA 6/IP67
LZ 1 large pipe	CPVC, Ultem, Nylon cord grip Polyethylene cable jacket; -40...194° F (-40...90° C)	300 ft (90 m)	8...48 in. (DN200...DN1200) <sup>3,4</sup>	33,000 (125,000)		NEMA 6/IP67
YZ 1 large pipe, submersible	CPVC, Ultem, Nylon cord grip Polyethylene cable jacket; -40...194° F (-40...90° C)	300 ft (90 m)	8...48 in. (DN200...DN1200) <sup>3,4</sup>	33,000 (125,000)		NEMA 6/IP68

1 Recommendations based on unlined, new pipes with water. Recommended pipe or tubing sizes vary with pipe conditions and fluids.

2 PVC, CPVC, HDPE, PTFE, PDVF, stainless steel, ductile iron, aluminum, brass naval, carbon steel copper.

3 Large pipe transducers are recommended for 8...12 in. pipes if normal velocity is expected to be greater than 12 ft/s (3.6 m/s).

4 Consult factory for larger pipe sizes.

## RTD Kits

Part Number	Description	Installation	RTD Type	Construction	Temperature Range
68996-001	RTD matched pair; 15 ft (4.5 m) cable	Pipe clamp, surface mount, IP54	Pt 1000, Class A	Aluminum body, silicone cable jacket	-58...356° F (14.4...180° C)
68996-002	RTD matched pair; 50 ft (15 m) cable				
68996-003	RTD matched pair; 100 ft (30 m) cable				

## Data Logging Storage

Part Number	Description
69032-001	MicroSD card, industrial grade, 8 GB

## SoloCUE Flow Device Manager Software

The flow meter *may* be programmed through the keypad or with SoloCUE software. If the meter is ordered without a display/keypad, the flow meter *must* be programmed with SoloCUE software. The software is used to configure, calibrate and communicate with UFM-DQG meters. Additionally, it has numerous troubleshooting tools to make diagnosing and correcting installation problems easier.

<b>SoloCUE</b>	Used to configure, calibrate and troubleshoot flow meters and control valves; Software is compatible with Windows 7, 8, 10
<b>USB Cable</b>	RC820648   USB 2.0 mini B connector to A connector, shielded

## DIMENSIONS

### Remote System Enclosure

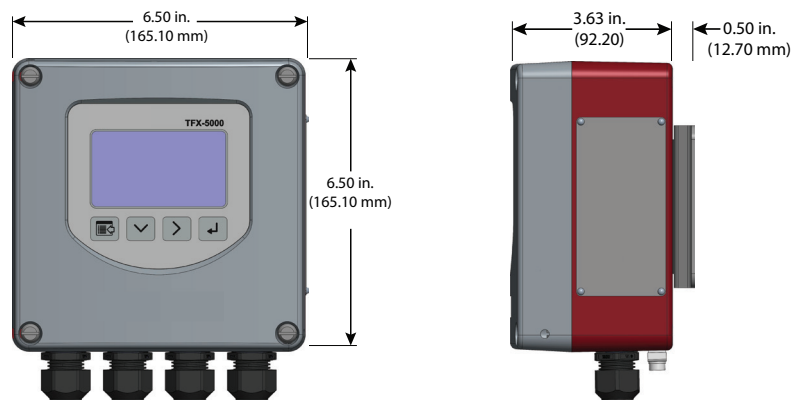

### Panel Mount Enclosure

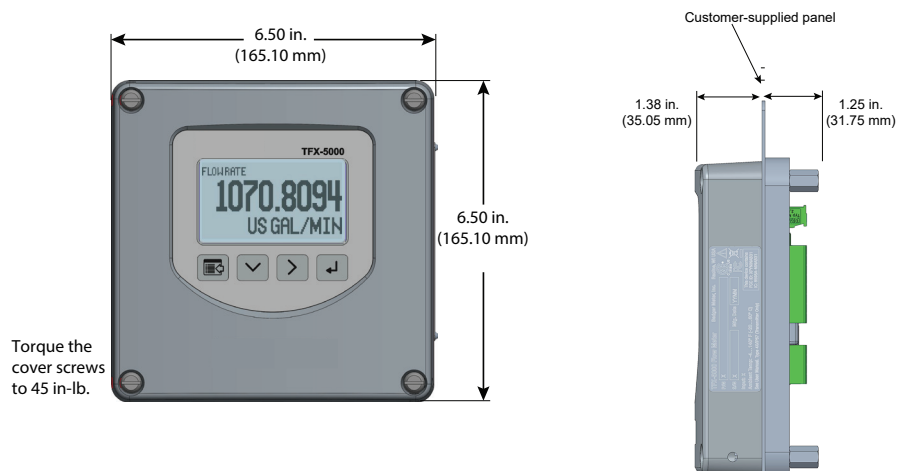

Consult factory for part number selection.

## Transducers

**Fixed Small Pipe**  
Pipes and Tubing 1/2...2 in. (12...50 mm)

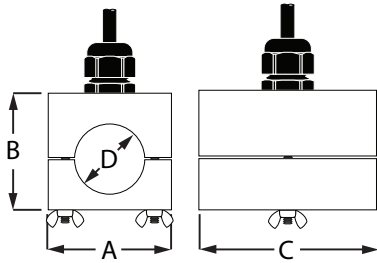

**RZ**  
Pipes Larger than 2 in. (50 mm)

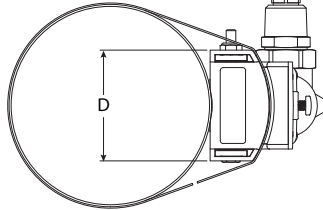
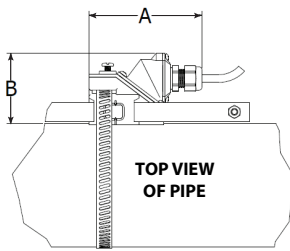

**Fixed Small Pipe U-Bolt Connections CF, CL ANSI/DN and Copper 2 in. (50 mm) Models**

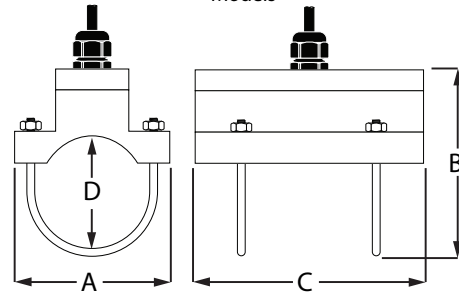

**NZ, WZ, HZ, LZ, YZ**  
Pipes Larger than 2 in. (50 mm)

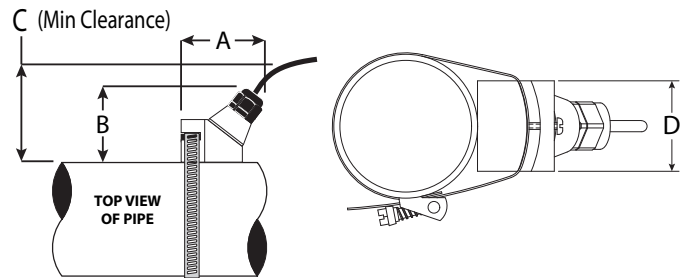

**UZ**  
Adjustable Small Pipe

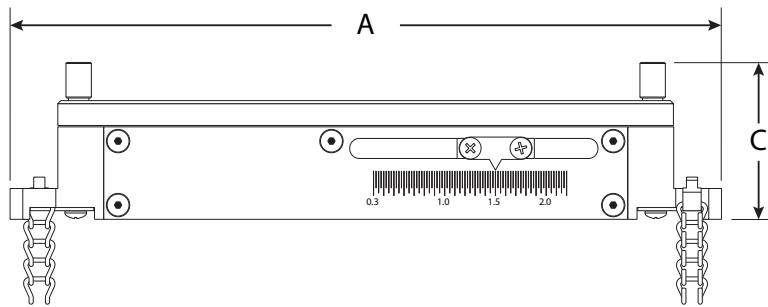

**Easy Rail (JZ, KZ)**

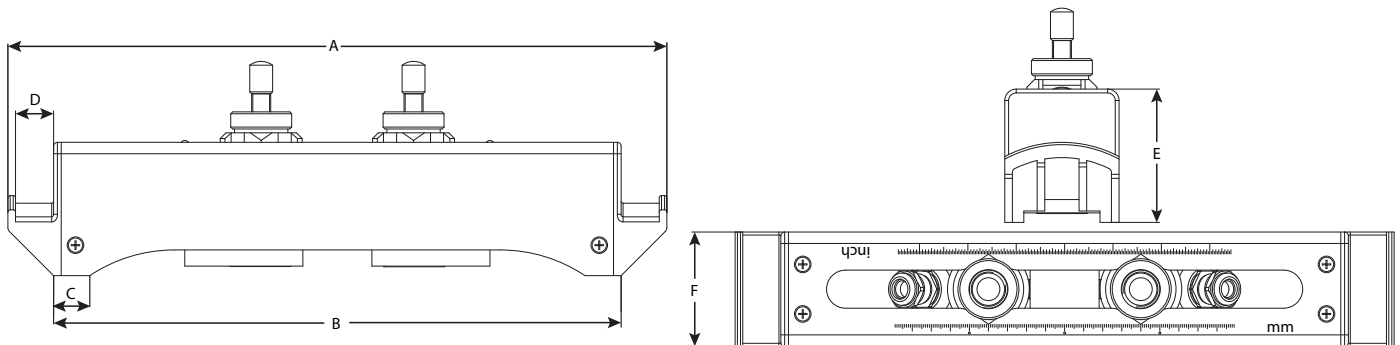

	<b>RZ</b>	<b>NZ, WZ</b>	<b>HZ</b>	<b>LZ, YZ</b>	<b>UZ</b>	<b>JZ</b>	<b>KZ</b>
<b>A</b>	3.75 in. (95 mm)	2.95 in. (74.9 mm)	2.95 in. (74.9 mm)	3.40 in. (86.4 mm)	7 in. (178 mm)	13.62 in. (345.95 mm)	19.92 in. (505.97 mm)
<b>B</b>	2.35 in. (60 mm)	2.75 in. (69.8 mm)	2.75 in. (69.8 mm)	2.94 in. (74.7 mm)	1.6 in. (42 mm)	11.73 in. (297.94 mm)	18.03 in. (457.96 mm)
<b>C</b>	—	3.00 in. (76.2 mm)	3.00 in. (76.2 mm)	3.20 in. (81.3 mm)	1.5 in. (39 mm)	0.75 in. (19.05 mm)	0.75 in. (19.05 mm)
<b>D</b>	2.19 in. (56 mm)	1.70 in. (43.2 mm)	1.71 in. (43.4 mm)	2.50 in. (63.5 mm)	—	0.79 in. (20.06 mm)	0.79 in. (20.06 mm)
<b>E</b>	—	—	—	—	—	2.76 in. (70.10 mm)	2.76 in. (70.10 mm)
<b>F</b>	—	—	—	—	—	2.36 in. (59.94 mm)	2.36 in. (59.94 mm)

## PART NUMBER CONSTRUCTION

### Part Number Construction for UFM-DQG Flow Meters for Pipes 2 in.

#### Smaller

[DQ] - [G] - [ ] - [ ] - [ ] - [ ] - [ ] - [ ] - [ ] - [XX] - [ ] - [ ] - [ ]

#### Model

UFM-DQG Ultrasonic Clamp-On Meter

DQ

#### Certification

General Area US/Canada, CE

G

#### Transducer Type<sup>1</sup>

1/2 inch ANSI Pipe  
3/4 inch ANSI Pipe  
1 inch ANSI Pipe  
1-1/4 inch ANSI Pipe  
1-1/2 inch ANSI Pipe  
2 inch ANSI Pipe  
1/2 inch Copper Tube  
3/4 inch Copper Tube  
1 inch Copper Tube  
1-1/4 inch Copper Tube  
1-1/2 inch Copper Tube  
2 inch Copper Tube  
Small pipe, universal (not available with conduit)

CA  
CB  
CC  
CD  
CE  
CF  
CG  
CH  
CT  
CJ  
CK  
CL  
UZ

#### Transmitter Type

110/220V AC Remote Mounted  
24V DC/AC Remote Mounted

R  
B

#### Display

Display and Keypad  
No Display/Keypad

S  
W

#### Remote Cable Length

15 feet (4.5 m)  
30 feet (9 m)  
50 feet (15 m)  
75 feet (23 m)  
100 feet (30 m)

AC  
AF  
AK  
AR  
BW

#### Conduit Type and Length (Conduit length is less than or equal to cable length)

None  
5 feet (1.5 m)  
15 feet (4.5 m)  
30 feet (9 m)  
50 feet (15 m)  
75 feet (23 m)  
100 feet (30 m)

WW  
AA  
AC  
AF  
AK  
AR  
BW

#### Hardware

1/2 in. NPT Threads, Poly cable glands  
1/2 in. NPT Threads, Nickel Plated Brass cable glands  
1/2 in. NPT Threads, no cable glands  
M20 Threads, Poly cable glands  
M20 Threads, Nickel Plated Brass cable glands M20  
Threads, no cable glands

S  
T  
N  
C  
D  
A

#### Endpoint Wiring Method

None

XX

#### Communication/Output

Standard Output (Modbus RTU or BACnet MS/TP field selectable)  
Standard Output plus Modbus TCP Ethernet  
Standard Output plus EtherNet/IP  
Standard Output plus BACnet/IP Ethernet  
Standard Output plus Aux Output

S  
T  
U  
V  
9

#### Units of Measure Totalizer/Flow Rate

Gallons/gallons per minute (field selectable, additional options available)

G

#### Testing & Tagging

Factory Calibrated  
Factory Calibrated/Stainless Steel Tag

F  
S

<sup>1</sup>Stainless steel tube 1/2...2 in. options are available.

**Part Number Construction for UFM-DQG Flow Meters for Pipes 2 in. and Smaller for Hazardous Locations**

DQ - B - - - - - - - - - - XX - - - - -

**Model**

UFM-DQG Ultrasonic Clamp-On Meter **DQ**

**Certification**

Hazardous Location, Class I, Division 2 **B**

**Transducer Type**<sup>1</sup>

1/2 inch ANSI Pipe CA  
 3/4 inch ANSI Pipe CB  
 1 inch ANSI Pipe CC  
 1-1/4 inch ANSI Pipe CD  
 1-1/2 inch ANSI Pipe CE  
 inch ANSI Pipe CF  
 1/2 inch Copper Tube CG  
 3/4 inch Copper Tube 1 CH  
 inch Copper Tube 1-1/4 CT  
 inch Copper Tube 1-1/2 CJ  
 inch Copper Tube 2 CK  
 inch Copper Tube CL

**Transmitter Type**

110/220V AC Remote Mounted **R**  
 24V DC/AC Remote Mounted **B**

**Display**

Display and Keypad **S**  
 No Display/Keypad **W**

**Remote Cable/Conduit Length**<sup>2</sup>

15 feet (4.5 m) AC AC  
 30 feet (9 m) AF AF  
 50 feet (15 m) AK AK  
 75 feet (23 m) AR AR  
 100 feet (30 m) BW BW

**Hardware**

1/2 in. NPT Threads, Poly cable glands **S**  
 1/2 in. NPT Threads, Nickel Plated Brass cable glands **T**  
 1/2 in. NPT Threads, no cable glands **N**  
 M20 Threads, Poly cable glands **C**  
 M20 Threads, Nickel Plated Brass cable glands M20 **D**  
 Threads, no cable glands **A**

**Endpoint Wiring Method**

None **XX**

**Communication/Output**

Standard Output (Modbus RTU or BACnet MS/TP field selectable) **S**  
 Standard Output plus Modbus TCP Ethernet **T**  
 Standard Output plus EtherNet/IP **U**  
 Standard Output plus BACnet/IP Ethernet **V**

**Units of Measure Totalizer/Flow Rate**

Gallons/gallons per minute (field selectable, additional options available) **G**

**Testing & Tagging**

Factory Calibrated **F**  
 Factory Calibrated/Stainless Steel **S**

<sup>1</sup> Stainless steel tube 1/2...2 in. options are available.

<sup>2</sup> For hazardous location units, Remote Cable and Conduit Length codes must match.

### Part Number Construction for UFM-DQG Flow Meters for Pipes Larger than 2 in.

	DQ	G								XX			
<b>Model</b>													
UFM-DQG Ultrasonic Clamp-On Meter	DQ												
<b>Certification</b>													
General Area US/Canada, CE	G												
<b>Transducer Type</b>													
Medium pipe, 2.5 in. (65 mm) or larger													RZ
Medium pipe, submersible, 2.5 in. (65 mm) or larger <sup>1</sup>													WZ
2.5...6 inches (65...150 mm) Easy Rail (not available with conduit)													JZ
2.5...12 inches (65...300 mm) Easy Rail (not available with conduit)													KZ
Medium pipe, high temperature (not available with conduit) Large pipe, 8 in. (200 mm) or larger													HZ
Large pipe, submersible, 8 in. (200 mm) or larger <sup>1</sup>													LZ
													YZ
<b>Transmitter Type</b>													
110/220V AC Remote Mounted													R
24V DC/AC Remote Mounted													B
<b>Display</b>													
Display and Keypad													S
No Display/Keypad													W
<b>Remote Cable Length</b>													
15 feet (4.5 m)													AC
30 feet (9 m)													AF
50 feet (15 m)													AK
75 feet (23 m)													AR
100 feet (30 m)													BW
150 feet (46 m)													BK
200 feet (61 m)													DW
250 feet (76 m)													DK
300 feet (90 m)													EW
<b>Conduit Type and Length (Conduit length is less than or equal to cable length.)</b>													
None													WW
5 feet (1.5 m)													AA
15 feet (4.5 m)													AC
30 feet (9 m)													AF
50 feet (15 m)													AK
75 feet (23 m)													AR
100 feet (30 m)													BW
150 feet (46 m)													BK
200 feet (61 m)													DW
250 feet (76 m)													DK
300 feet (90 m)													EW
<b>Hardware</b>													
1/2 in. NPT Threads, Poly cable glands													S
1/2 in. NPT Threads, Nickel Plated Brass cable glands													T
1/2 in. NPT Threads, no cable glands													N
M20 Threads, Poly cable glands													C
M20 Threads, Nickel Plated Brass cable glands M20													D
Threads, no cable glands													A
<b>Endpoint Wiring Method</b>													
None													XX
<b>Communication/Output</b>													
Standard Output (Modbus RTU or BACnet MS/TP field selectable)													S
Standard Output plus Modbus TCP Ethernet													T
Standard Output plus EtherNet/IP													U
Standard Output plus BACnet/IP Ethernet													V
Standard Output plus Aux Output													9
<b>Units of Measure Totalizer/Flow Rate</b>													
Gallons/gallons per minute (field selectable, additional options available)													G
<b>Testing &amp; Tagging</b>													
Factory Calibrated													F
Factory Calibrated/Stainless Steel Tag													S

<sup>1</sup> Submersible transducer cables use two conduit openings.





## Part Number Construction for UFM-DQG Energy Meters for Pipes Larger than 2 in.

	DR	G									XX				
<b>Model</b>	UFM-DQG Ultrasonic Clamp-On Meter														
<b>Certification</b>	General Area US/Canada, CE														
<b>Transducer Type</b>	Medium pipe, 2.5 in. (65 mm) or larger RZ														
	Medium pipe, submersible, 2.5 in. (65 mm) or larger <sup>1</sup> WZ														
	2.5...6 inches (65...150 mm) Easy Rail (not available with conduit) JZ														
	2.5...12 inches (65...300 mm) Easy Rail (not available with conduit) KZ														
	Medium pipe, high temperature (not available with conduit) Large pipe, 8 in. (200 mm) or larger HZ														
	Large pipe, submersible, 8 in. (200 mm) or larger <sup>1</sup> LZ														
	YZ														
<b>Transmitter Type</b>	110/220V AC Remote Mounted R														
	24V DC/AC Remote Mounted B														
<b>Display</b>	Standard S														
	No Display/Keypad W														
<b>Remote Cable Length</b>	15 feet (4.5 m) AC														
	30 feet (9 m) AF														
	50 feet (15 m) AK														
	75 feet (23 m) AR														
	100 feet (30 m) BW														
	150 feet (46 m) BK														
	200 feet (61 m) DW														
	250 feet (76 m) DK														
	300 feet (90 m) EW														
<b>Conduit Type and Length (Conduit length is less than or equal to cable length)</b>	None WW														
	5 feet (1.5 m) AA														
	15 feet (4.5 m) AC														
	30 feet (9 m) 50 AF														
	feet (15 m) 75 AK														
	feet (23 m) 100 AR														
	feet (30 m) 150 BW														
	feet (46 m) 200 BK														
	feet (61 m) 250 DW														
	feet (76 m) 300 DK														
	feet (90 m) EW														
<b>RTD Type</b>	Surface, Commercial C														
	None (user provided) X														
<b>RTD Length</b>	15 feet (4.5 m) AC														
	50 feet (15 m) AK														
	100 feet (30 m) None BW														
	(user provided) WW														
<b>Hardware</b>	1/2 in. NPT Threads, Poly cable glands S														
	1/2 in. NPT Threads, Nickel Plated Brass cable glands T														
	1/2 in. NPT Threads, no cable glands N														
	M20 Threads, Poly cable glands C														
	M20 Threads, Nickel Plated Brass cable glands M20 D														
	Threads, no cable glands A														
<b>Endpoint Wiring Method</b>	None XX														
<b>Communication/Output</b>	Standard Output (Modbus RTU or BACnet MS/TP field selectable) S														
	Standard Output plus Modbus TCP Ethernet T														
	Standard Output plus EtherNet/IP U														
	Standard Output plus BACnet/IP Ethernet V														
	Standard Output plus Aux Output 9														
<b>Units of Measure Totalizer/Flow Rate</b>	Gallons/gallons per minute (field selectable, additional options available) G														
<b>Units of Measure Energy Totalizer/Rate</b>	Kilowatt-hour/Kilowatt (field selectable, additional options available) R														
<b>Testing &amp; Tagging</b>	Factory Calibrated F														
	Factory Calibrated/Stainless Steel Tag S														

<sup>1</sup> Submersible transducer cables use two conduit openings.

